

podis[®] MOT FP C 2I2IO/RS 485 SEW
(Ref.-No. **83.252.xxyy.2**)

podis[®] MOT FP CM 2I2IO/RS 485 SEW
(Ref.-No. **83.252.xxyy.4**)

podis[®] MOT FP CP 2I2IO/RS 485 SEW
(Ref.-No. **83.252.0005.2**)

Decentralized PROFIBUS field distributors

Operation manual

Doc. No. BA000349

Revision A

© 2007 Wieland Electric GmbH

Dear customer,

Congratulations on your new components of the podis decentral automation system. You are the owner of a PROFIBUS-DP technology product. It allows for the control of drives in industrial systems.

Please familiarize yourself with this documentation. It contains all the information and help required for proper operation of your podis system. If you still have questions or require any help, our experts are gladly at your disposal using the contact options listed below.

Hotline **Technical Service** (technical questions about accessories, operating principle, product features and application options of the podis energy bus system):

Ph.: +49 (0)9 51 / 93 24-9 98

AT.TS@wieland-electric.com

Hotline **Sales** (availability, delivery time, and prices):

Ph.: +49 (0)9 51 / 93 24-9 90

Fax: +49 (0)9 51 / 93 24-9 64

AT.info@wieland-electric.com

1.1 Version management

| Document BA000349 | | |
|------------------------|------------|----------|
| Version | Date | Author |
| First Edition (Rev. A) | 15.05.2007 | T. Kluck |
| | | |

1.2 Additional documents

Documents from Wieland Electric

Wieland Electric provides the following documents for the podis® system:

- podis®CON

Documents from suppliers

The following documents are provided by suppliers:

- MOVIMOT® MM03C-MM3XC operating instructions from SEW-Eurodrive
- MOVIMOT® MM03B-MM30B operating instructions from SEW-Eurodrive
- PROFIBUS-DP master operating instructions

Trademarks used

All trademarks listed in this documentation and any trademarks copyrighted by third-parties are unrestrictedly subject to the respective legal provisions and the rights of ownership of the respective registered owners.

The simple mentioning by itself does not imply that the trademark is not protected by the rights of others!

| | |
|--|------------|
| 1 General Information | 1.1 |
| 1.1 Version management | 1.2 |
| 1.2 Additional documents | 1.2 |
| Documents from Wieland Electric | 1.2 |
| Documents from suppliers | 1.2 |
| Trademarks used | 1.2 |
| 1.3 Table of contents | 1.3 |
| 1.4 About these operating instructions | 1.5 |
| Content of these operating instructions | 1.5 |
| Intended users of these operating instructions | 1.5 |
| Safety information | 1.5 |
| 1.5 Intended use | 1.6 |
| Selection of personnel and qualifications | 1.7 |
| Obvious misuse | 1.7 |
| 1.6 Project planning, programming, installation, commissioning, and operation | 1.7 |
| 1.7 Maintenance and servicing | 1.8 |
| 1.8 Prevention of property damages and bodily injury | 1.8 |
| 1.9 Dangers from electrical energy | 1.8 |
| 2 podis®MOT FP C/CM/CP 2I2IO/RS485 SEW Device Description | 2.1 |
| 2.1 Variant overview | 2.1 |
| 2.2 General | 2.1 |
| 2.3 Mechanical design / housing | 2.2 |
| 2.4 Connections | 2.2 |
| Connections at podis®MOT FP C 2I2IO/RS485 SEW | 2.2 |
| Connections at podis®MOT FP CM 2I2IO/RS485 SEW | 2.3 |
| Connections at podis®MOT FP CP 2I2IO/RS485 SEW | 2.3 |
| PROFIBUS interface | 2.4 |
| Connections for sensor cables | 2.4 |
| 2.5 Controls | 2.5 |
| PROFIBUS-DP addressing | 2.5 |
| 2.6 Display elements | 2.5 |
| Status LEDs | 2.5 |
| 2.7 Technical Information | 2.6 |
| Installation dimensions of FP C 2I2IO/RS485 SEW | 2.6 |
| Installation dimensions of FP CM 2I2IO/RS485 SEW | 2.7 |
| Installation dimensions of FP CP 2I2IO/RS485 SEW | 2.8 |
| Block diagram of FP C 2I2IO/RS485 SEW | 2.9 |
| Block diagram of FP CM 2I2IO/RS485 SEW | 2.10 |
| Block diagram of FP CP 2I2IO/RS485 SEW | 2.11 |
| 3 Mechanical Installation (Assembly) | 3.1 |
| 3.1 Prerequisites | 3.1 |
| 3.1 Installation on substructure | 3.1 |
| 4 Electrical Installation | 4.1 |
| General safety notes | 4.1 |
| 4.1 Connection to the podis® energy bus | 4.1 |
| Procedure | 4.3 |
| 4.2 Connection of sensor cables | 4.4 |
| 4.3 Connection of PROFIBUS cables | 4.5 |

| | | |
|----------|--|------------|
| 4.4 | MOVIMOT® connection | 4.6 |
| | Cable ends..... | 4.6 |
| | Connector assignment of HAN modular insert..... | 4.6 |
| | Connector assignment of recos FLEX insert | 4.7 |
| | Connector assignment of revos MOT..... | 4.8 |
| | Connection of open cable end..... | 4.8 |
| 5 | Commissioning | 5.1 |
| | GSD file | 5.1 |
| 5.1 | Selection of the installation menu | 5.1 |
| 5.2 | Selection of the GSD files | 5.2 |
| 5.3 | Copying the image files..... | 5.2 |
| 5.4 | Updating the hardware catalog..... | 5.2 |
| 5.5 | Inserting a new hardware configuration (if needed) | 5.3 |
| | Selecting the hardware catalog | 5.3 |
| | Selecting the mounting rail and power supply..... | 5.3 |
| | Selecting the CPU | 5.3 |
| 5.6 | Inserting the DP slave in the PROFIBUS network..... | 5.5 |
| 5.7 | Parameter setting of podis®MOT properties..... | 5.7 |
| | “General” tab | 5.7 |
| | “Parameter Setting” tab..... | 5.8 |
| | Hex parameter setting | 5.8 |
| 5.8 | Preparing the MOVIMOT® | 5.9 |
| 5.9 | Addressing the field distributor..... | 5.9 |
| | PROFIBUS address setting..... | 5.9 |
| | Procedure | 5.9 |
| 5.10 | Assignment of inputs and outputs in process image..... | 5.10 |
| 5.11 | PROFIBUS functions..... | 5.10 |
| | DP configuration | 5.10 |
| 5.12 | Commissioning the field distributor..... | 5.11 |
| 6 | Operation..... | 6.1 |
| 6.1 | Functional check | 6.1 |
| | Operating state..... | 6.1 |
| 7 | Diagnostics (and Fault Removal)..... | 7.1 |
| 7.1 | Fault removal..... | 7.1 |
| 7.2 | Central diagnostics via PROFIBUS-DP | 7.2 |
| | Error response to RS485 interruption | 7.2 |
| | Error response to missing or faulty supply voltage | 7.2 |
| | PROFIBUS-DP slave diagnostics data | 7.3 |
| | Switching alarms on and off | 7.3 |
| 7.3 | Replacing the electronics module | 7.4 |
| 8 | MOVILINK® Device Profile..... | 8.1 |
| 8.1 | Coding of process data..... | 8.1 |
| 8.2 | Process output data..... | 8.2 |
| 8.3 | Process input data | 8.5 |
| 8.4 | Program example..... | 8.6 |
| 9 | Appendix..... | 9.1 |
| 9.1 | Technical data..... | 9.1 |
| 9.2 | Ordering information | 9.2 |
| | Order number key..... | 9.2 |
| | Ordering information | 9.3 |

1.4 About these operating instructions

These operating instructions provide support for the installation, commissioning, and maintenance of the podis MOT FP C/CM/CP 2I2IO/RS485 SEW.

It contains instructions for programming, configuring, and parameterizing the field distributor.

These operating instructions contain the information required for the as-intended use of the product described herein

podis systems may be installed only by qualified personnel while adhering to the respective regulations of the VDE (Association of German Electricians). For this reason, these operating instructions are intended for technically qualified personnel (e.g. skilled persons, electrical engineers) who is either

- familiar with the safety concepts of automation technology as project planning and programming personnel, or
- trained in handling equipment of automation technology as operating personnel and familiar with the contents of these instructions pertaining to the operation, or
- trained as installation, commissioning, and maintenance personnel which enables them to perform operations on equipment of automation technology and who is authorized to commission, ground, and identify electrical circuits and devices or systems according to the standards of safety engineering.

Special requirements are:

- Basic knowledge of PROFIBUS-DP technology
- Basic knowledge of decentral drive systems

These operating instructions use different safety instructions depending upon the hazard potential:

| DANGER |
|---|
| "Danger" identifies a direct dangerous situation or a direct dangerous condition which, if not avoided, causes serious injuries or death. The use of this sign is restricted to extreme situations. |



| WARNING |
|---|
| "Warning" identifies a potentially dangerous situation or a potentially dangerous condition which, if not avoided, may cause serious injuries or death. |



| CAUTION |
|---|
| "Caution" identifies a potentially dangerous situation or a potentially dangerous condition which, if not avoided, may cause minor or non-serious injuries or death. "Caution" is also used to warn about unsafe handling or obvious misuse. "Caution" is also used for situations in which property damage or personal injuries may occur. |



Content of these operating instructions

Intended users of these operating instructions

Safety information

NOTE

"Notice" identifies information that is directly or indirectly related to the safety of personnel or property. It is not used for dangers or dangerous situations.

"Danger" or "warning" generally refers to a risk to life or limb. In this case, property damages are considered only if there is also a risk to bodily injury corresponding to the danger level.

1.5 Intended use

The field distributors podis MOT FP C 2I2IO/RS485 SEW, podis MOT FP CM 2I2IO/RS485 SEW and podis MOT FP CP 2I2IO/RS485 SEW are PROFIBUS-DP actuator/sensor module on the podis energy bus for the control and energy supply of SEW MOVIMOT AC motors with integrated frequency inverter and serial communication (RS485)

The energy bus systems feature a state-of-the-art design and follow approved safety regulations. Nevertheless, their use may create dangers to life and limb of users or third parties or impairments of machinery, systems or other tangible assets.

The energy bus systems may be used only in a technically flawless condition and for proper, safety-conscious and risk-conscious use while observing the operating instructions. The flawless and safe operation of the controller assumes proper transport, proper storage and assembly as well as careful operation and maintenance. In particular, malfunctions that could impair the safety must be removed immediately.

For the intended use of the energy bus systems, the instructions described in these operating instructions for the mechanical and electrical assembly, commissioning and operation must be observed.

Never install or commission damaged products. Damages should be filed immediately with the transport company.

Before applying supply voltage to the field distributor, the top part (electronics cover) must be installed and fastened onto the bottom part.

Before removing the top part (electronics cover), the energy bus segment must be de-energized. Dangerous voltages can be present up to 1 minute after disconnecting the supply (voltage in the DC links for decentral frequency inverters or power supplies).

During operation, do not disconnect or connect any plug connections to the attached consumers.

For the project planning, installation and commissioning of the energy bus systems as part of the supply of machines and their controllers, the machine manufacturer and user must observe the safety regulations of machine directive 89/392/EWG and, for the specific application case, the applicable national accident prevention regulations. Observe the applicable safety and accident prevention regulations for the respective application cases, such as the machine protection directive. All safety devices of the controlled machine must be implemented in such a way that they operate independent of the controller. EMERGENCY OFF devices according to IEC 204 (corresponding to DIN VDE 113) must remain effective in all operating modes of the system. In an EMERGENCY OFF case, the supply voltages of all switching elements controlled by the controller must be switched off.

The field distributor is intended exclusively for automation tasks in industrial systems and machines. Any other or additional use beyond that is considered to be unintended use. The manufacturer is not liable for any damages resulting from it.

For the intended use of the automation systems, the instructions described in these operating instructions for the mechanical and electrical assembly, commissioning and operation must be observed.

All project planning, programming, installation, commissioning, operation and maintenance work in conjunction with the podis electronics products may be performed only by trained personnel (e.g. skilled persons, electrical engineers). The project planning and programming personnel must be familiar with the safety concepts of automation technology.

The operating personnel must be trained in handling the controller and be familiar with the operating instructions. The installation, commissioning and maintenance personnel must have training that allows them to perform operations on automation systems.

Warnings about obvious misuse and unsafe handling are featured at the corresponding locations.

Selection of personnel and qualifications

Obvious misuse

NOTE

The manufacturer is not liable for damages resulting from improper use.

1.6 Project planning, programming, installation, commissioning, and operation

With respect to their application, the field distributors of the podis series are generally a part of larger systems or plants in which machines are controlled. For the project planning, installation and commissioning of the podis systems as part of the control of machines, the machine manufacturer and user must, therefore, observe the safety regulations of machine directive 89/392/EWG. For the specific application case, the national accident prevention regulations apply, such as VBG 4.0.

All safety devices of the controlled machine must be implemented in such a way that they operate independent of the controller. EMERGENCY OFF devices must remain effective in all operating modes of the controller. In an EMERGENCY OFF case, the supply voltages of all switching elements controlled by the controller must be switched off. A safety relay can be used for this purpose.

Precautions must be taken that an interrupted control program can be properly started again after voltage dips and power failures. No dangerous operating states may occur, not even briefly. If necessary, EMERGENCY OFF must be forced. To prevent a an open circuit on the signal side from causing undefined states in the controller, the corresponding safety measures must be taken for the I/O coupling with respect to hardware and software. Devices of the control technology and their controls must be installed in such a way that they are sufficiently protected against inadvertent activation.

The automation devices must be de-energized before they are assembled or disassembled or the design is changed.

1.7 Maintenance and servicing

If the active device requires measuring or testing work, the regulations and execution instructions of accident prevention regulation VBG 4.0 must be observed. A suitable electric tool must be used.



WARNING

- Repairs involving control components may be performed only by authorized repair locations. Unauthorized opening and tampering or improper repairs can cause physical injuries or property damages.
- Before opening the device, always disconnect the connection to the supply system.
- Control modules may be changed only in the de-energized state. Disassembly and assembly must be carried out according to the mechanical equipment mounting directives.

1.8 Prevention of property damages and bodily injury

The voltage values must not be less than or greater than the voltage values listed in the technical data since it may lead to malfunctions or damage to the devices.

If errors occur in the automation equipment that may cause heavy property damages or even bodily injuries, additional external safety measures must be taken or devices must be created that will ensure or force a defined operating state in case of an error (e.g. by means of independent limit switches, mechanical interlocks, etc.).



1.9 Dangers from electrical energy

WARNING

Opening the housing provides access to certain parts that may carry dangerous voltages.

The user must ensure that unauthorized and improper interventions are prevented.

The personnel must be thoroughly familiar with all danger sources and measures for commissioning and maintenance according to the information in the operating instructions.

2 **podis®MOT FP C/CM/CP 2I2IO/ RS485 SEW Device Description**

2.1 Variant overview



podis MOT FP C 2I2IO
83.252.xxyy.2

revos connector interface for connecting the field devices
Preassembled hybrid cable to the consumer (drive)



podis MOT FP CM 2I2IO
83.252.xxyy.4

same as 83.252.xxyy.2, but with repair switch



podis MOT FP CP 2I2IO
83.252.0005.2

revosMOT connector interface directly at podis® field distributor

2.2 General

The field distributors podis MOT FP C 2I2IO/RS485 SEW, podis MOT FP CM 2I2IO/RS485 SEW and podis MOT FP CP 2I2IO/RS485 SEW are PROFIBUS-DP actuator/sensor module on the podis energy bus for the control and energy supply of SEW MOVIMOT AC motors with integrated frequency inverter and serial communication (RS485)

The communication between field distributor and MOVIMOT is carried out via a galvanically isolated RS485 interface. MOVILINK profile from SEW is the protocol being used.

The PROFIBUS controller controls the complete data exchange with the PROFIBUS master. The isolated RS485 interface serves as transfer medium.

The connection between field distributor and drive is implemented using a prefabricated hybrid cable and plug connector.

Using prefabricated M12 connecting lines allows for connecting 2-wire and 3-wire sensors to the four free inputs. The sensors are supplied from the field distributor via the PROFIBUS interface.

Addressing the field distributor is carried out via the settings of two rotary switches. The digital inputs are read via the M12 sockets without being processed by the operating system and transferred to the PROFIBUS master upon request.

To display the current switching state and the status of the inputs, each channel features an LED in the housing cover of the field distributor.

The contact to the energy bus is established via penetrating screws.

2.3 Mechanical design / housing

Based on its mechanical design, the housing of the podis MOT FP C/CM/CP 2I2IO/RS485 SEW is divided into an upper and a lower part.

The upper part contains the electronics for controlling the drive.

The upper part is fastened onto the lower part using four screws.

The base contains the connection technology for the podis energy bus.

The electrical connection between hood and base is implemented via a cable harness from the base connected to a PCB pluggable connector in the hood.

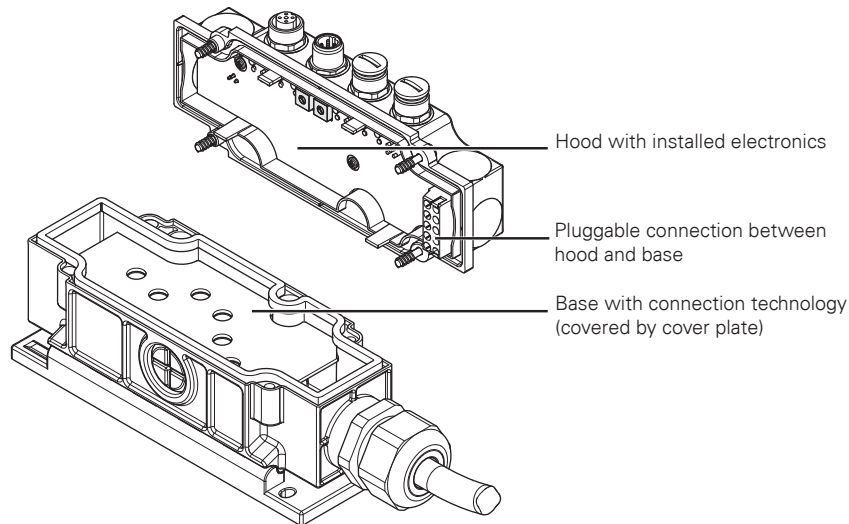

podis®MOT FP C 2I2IO (opened), FP CM 2I2IO and FP CP 2I2IO similar

Connections at the podis®MOT FP C 2I2IO/RS485 SEW

2.4 Connections

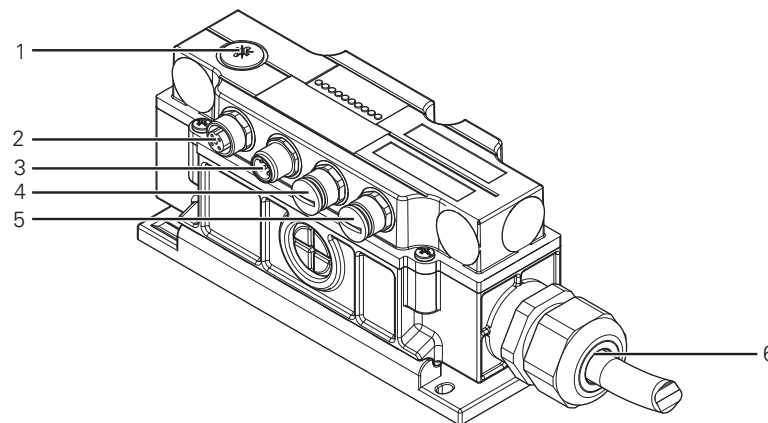

Connections at the podis®MOT FP C 2I2IO/RS485 SEW

- | | | |
|---|----------------|------------------------|
| 1 | ----- | Not assigned |
| 2 | DP-OUT (X2) | PROFIBUS-DP output |
| 3 | DP-IN (X3) | PROFIBUS-DP input |
| 4 | IO2 / IO3 (X4) | Digital inputs/outputs |
| 5 | IO / I1 (X5) | Digital inputs |
| 6 | X1 | Interface to the drive |

2 | podis®MOT FP C/CM/CP 2I2IO/RS485 SEW Device Description

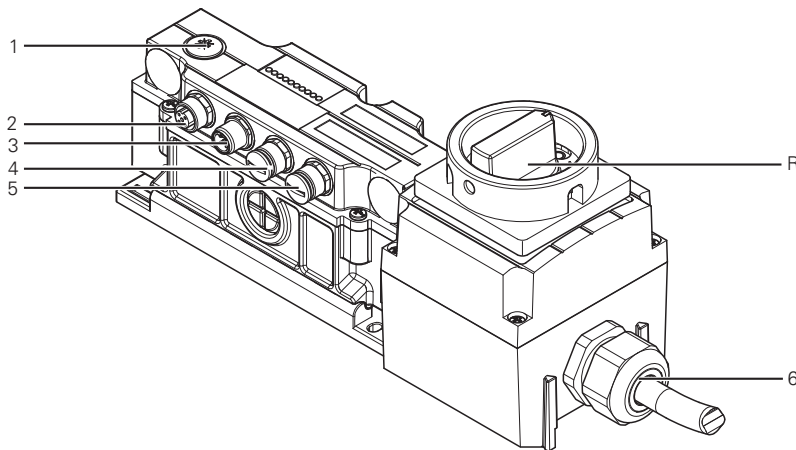

Connections at the podis®MOT FP CM 2I2IO/RS485 SEW

Connections at the podis®MOT FP CM 2I2IO/RS485 SEW

| | | |
|---|----------------|------------------------|
| 1 | ----- | Not assigned |
| 2 | DP-OUT (X2) | PROFIBUS-DP output |
| 3 | DP-IN (X3) | PROFIBUS-DP input |
| 4 | IO2 / IO3 (X4) | Digital inputs/outputs |
| 5 | I0 / I1 (X5) | Digital inputs |
| 6 | X1 | Interface to the drive |
| R | | Repair switch |

The podisMOT FP CM 2I2IO/RS485 SEW also features a repair switch.

If the field distributor version features a repair switch, it is used to disconnect the voltage supply for maintenance and repair work on the attached motor.

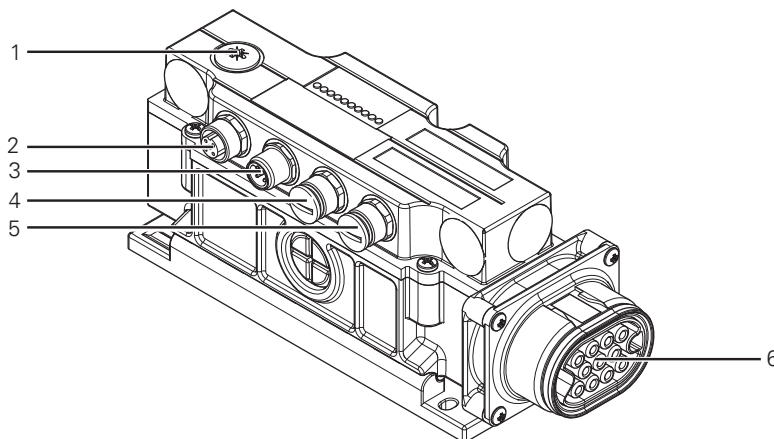

Connections at the podis®MOT FP CP 2I2IO/RS485 SEW

Connections at the podis®MOT FP CP 2I2IO/RS485 SEW

| | | |
|---|----------------|------------------------|
| 1 | ----- | Not assigned |
| 2 | DP-OUT (X2) | PROFIBUS-DP output |
| 3 | DP-IN (X3) | PROFIBUS-DP input |
| 4 | IO2 / IO3 (X4) | Digital inputs/outputs |
| 5 | I0 / I1 (X5) | Digital inputs |
| 6 | X1 | Interface to the drive |

PROFIBUS interface

PROFIBUS socket X2

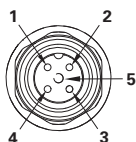

| Pin | Brief description | Note |
|-----|-------------------|-------|
| 1 | V _P | |
| 2 | A | BUS-N |
| 3 | Data GND | |
| 4 | B | BUS-P |
| 5 | Shield | PE |

PROFIBUS connector X3

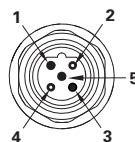

Connections for sensor cables

2-wire and 3-wire sensors can be connected to the podisMOT FP C/CM/CP 2I2IO/RS485 SEW via M12 sockets X4 and X5.

Digital inputs X4 and X5

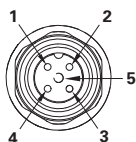

| Pin | Brief description | X4 | X5 |
|-----|-------------------|----|----|
| 1 | 24 V | | |
| 2 | Input | I3 | I1 |
| 3 | 0 V | | |
| 4 | Input | I2 | I0 |
| 5 | PE | | |

Digital outputs at X4

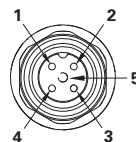

| Pin | Brief description | X4 |
|-----|-------------------|----|
| 1 | 24 V | |
| 2 | Output | O3 |
| 3 | 0 V | |
| 4 | Output | O2 |
| 5 | PE | |

NOTE

Each I/O channel can be operated alternatively as input or output. Therefore, address space is reserved for both input and output in the process image. Make sure that a channel used as input (e.g. an initiator) is not used as output channel at the same time.

In contrast, an output channel can be re-read as input, hereby enabling the SPS to monitor the switching function.



CAUTION

No 24 V-voltage may be applied to the combination channel X4!

Otherwise, a current feed back to the supply voltage connection of the module will occur via the output circuit. As a consequence, malfunctioning can appear, or the output circuit can be destroyed.



WARNING

Unused connections must be fitted with M12 caps to ensure enclosure IP65.

2.5 Controls

The podis MOT does not feature any controls.

Addressing is carried out via the setting of the two rotary switches in the electronics cover of

PROFIBUS-DP addressing

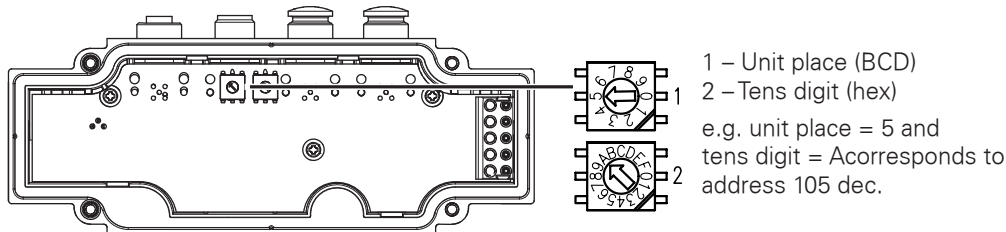

PROFIBUS-DP addressing switches (rotary switches) in electronics cover

the field distributor.

NOTE

The two rotary switches adjust the PROFIBUS-DP address in the range from 1 to 126. Address "0" is set in the delivery state. Of no address between 1 and 126 is set, the system adopts address "126". In this case, the green "RUN" LED flashes.

2.6 Display elements

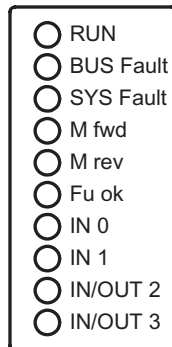

| No. | Color | Designation | Meaning | I/O bit |
|-----|--------|-------------|---------------------------|---------|
| 1 | green | RUN | Bus is operating | |
| 2 | red | BUS Fault | A fault on the bus | |
| 3 | yellow | SYS Fault | Connection to the MOVIMOT | |
| 4 | yellow | M fwd | CW rotation of motor | |
| 5 | yellow | M rev | CCW rotation of motor | |
| 6 | yellow | Fu ok | Motor is operational | |
| 7 | yellow | IN 0 | M12 input (X5) | Bit 0 |
| 8 | yellow | IN 1 | M12 input (x5) | Bit 1 |
| 9 | yellow | IN/OUT 2 | M12 input/output | Bit 2 |
| 10 | yellow | IN/OUT 3 | M12 input/output | Bit 3 |

Status LEDs

The status LEDs on the housing cover provide information about the status of the module. See also section 7.1, "Diagnostics (and fault removal)".

Installation dimensions of podis®MOT FP C 2I2IO/RS485 SEW

2.7 Technical Information

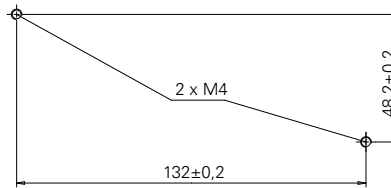
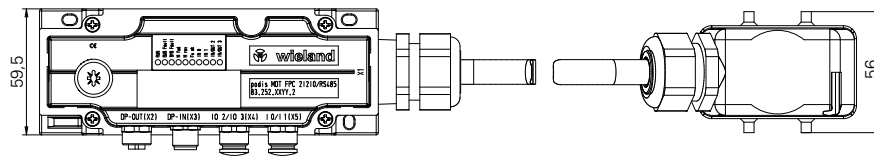
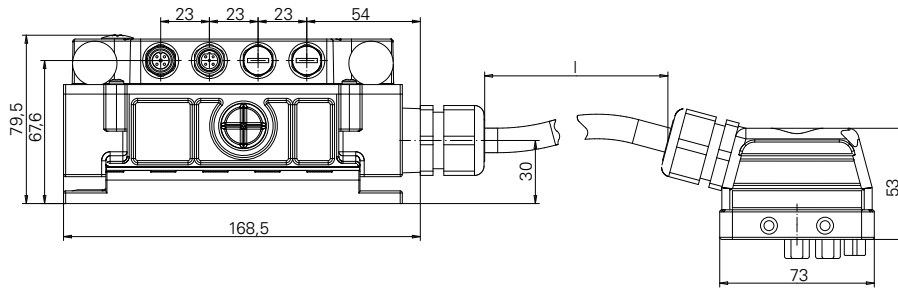

2 | podis® MOT FP C/CM/CP 2I2IO/RS485 SEW Device Description

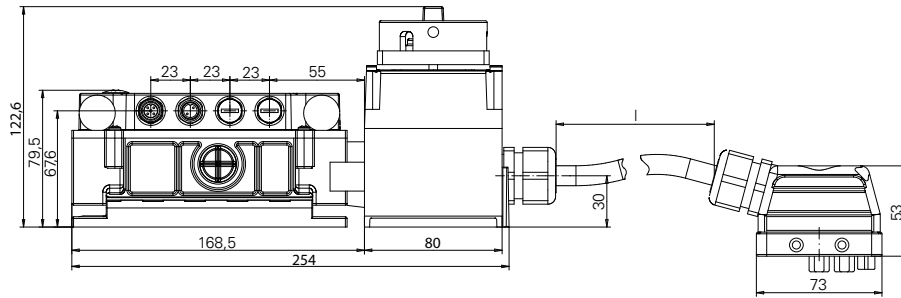

Installation
dimensions of
podis®MOT FP
CM 2I2IO/RS485
SEW

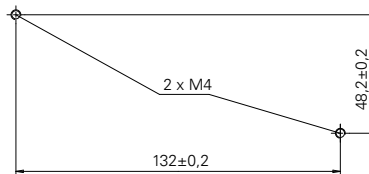
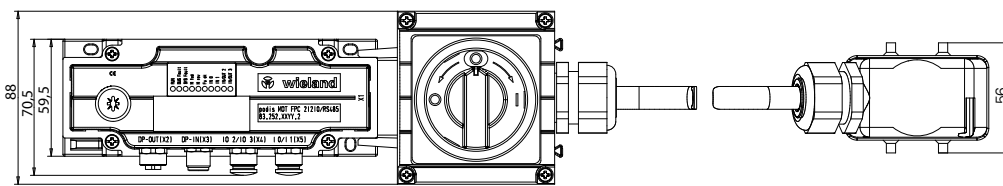

podis® MOT FP C/CM/CP 2I2IO/RS485 SEW Device Description | 2

Installation
Dimensions of
podis®MOT FP
CP 2I2IO/RS485
SEW

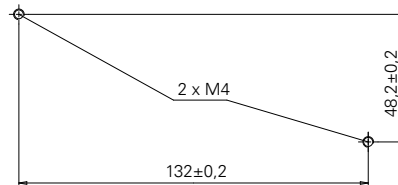
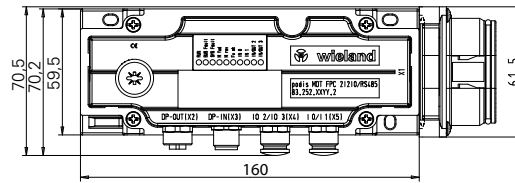
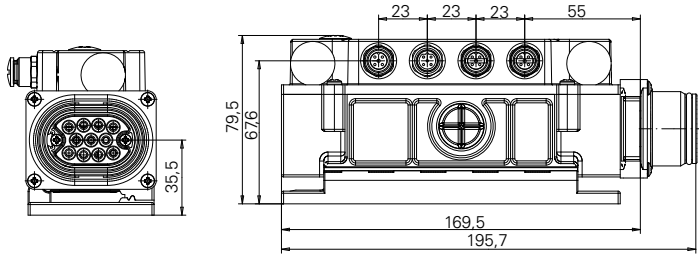

2 | podis® MOT FP C/CM/CP 2I2IO/RS485 SEW Device Description

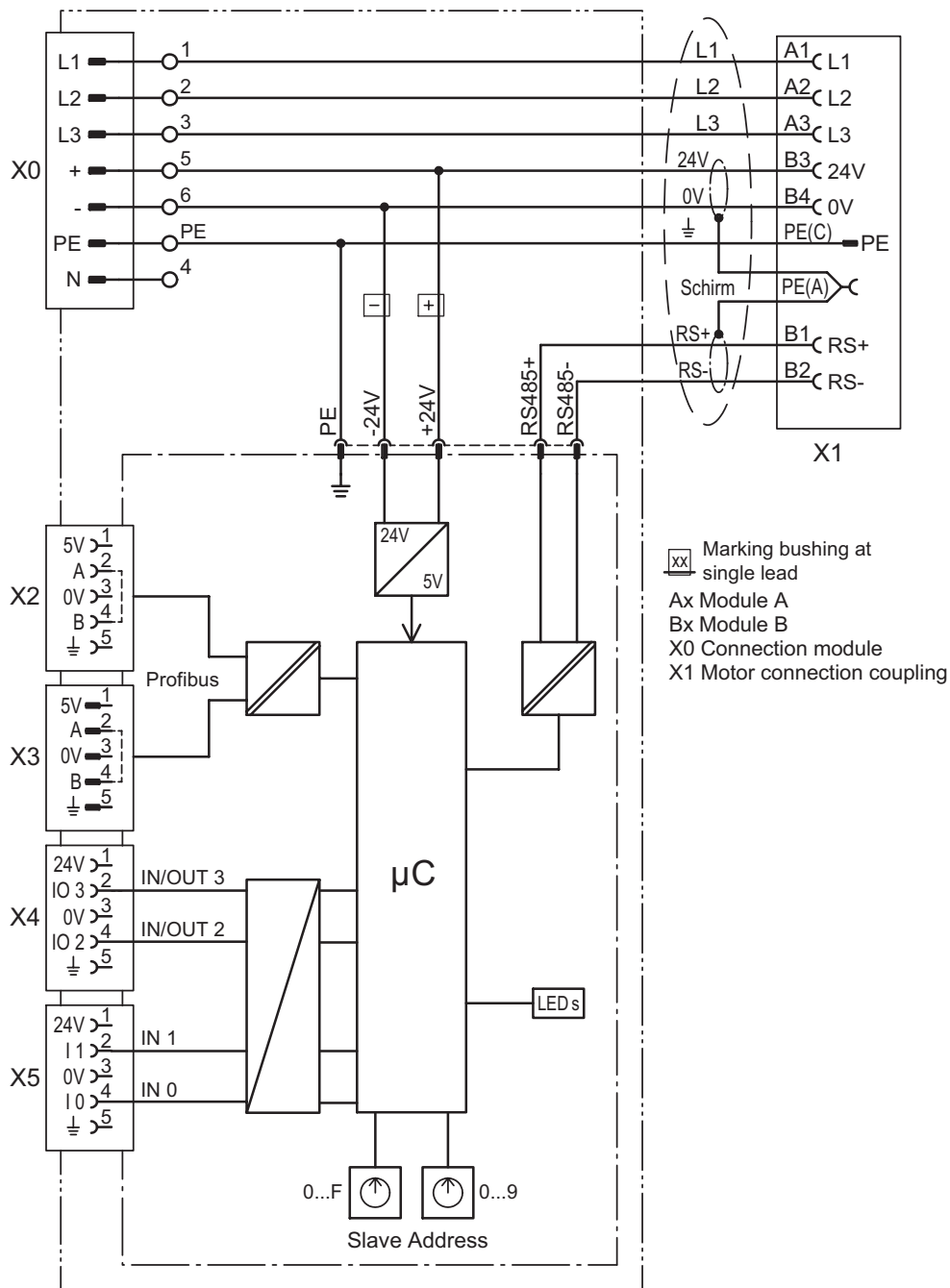

Block diagram of podis® MOT FP C 2I2IO/RS485 SEW

Block diagram of podis®MOT FP CM 2I2IO/RS485 SEW

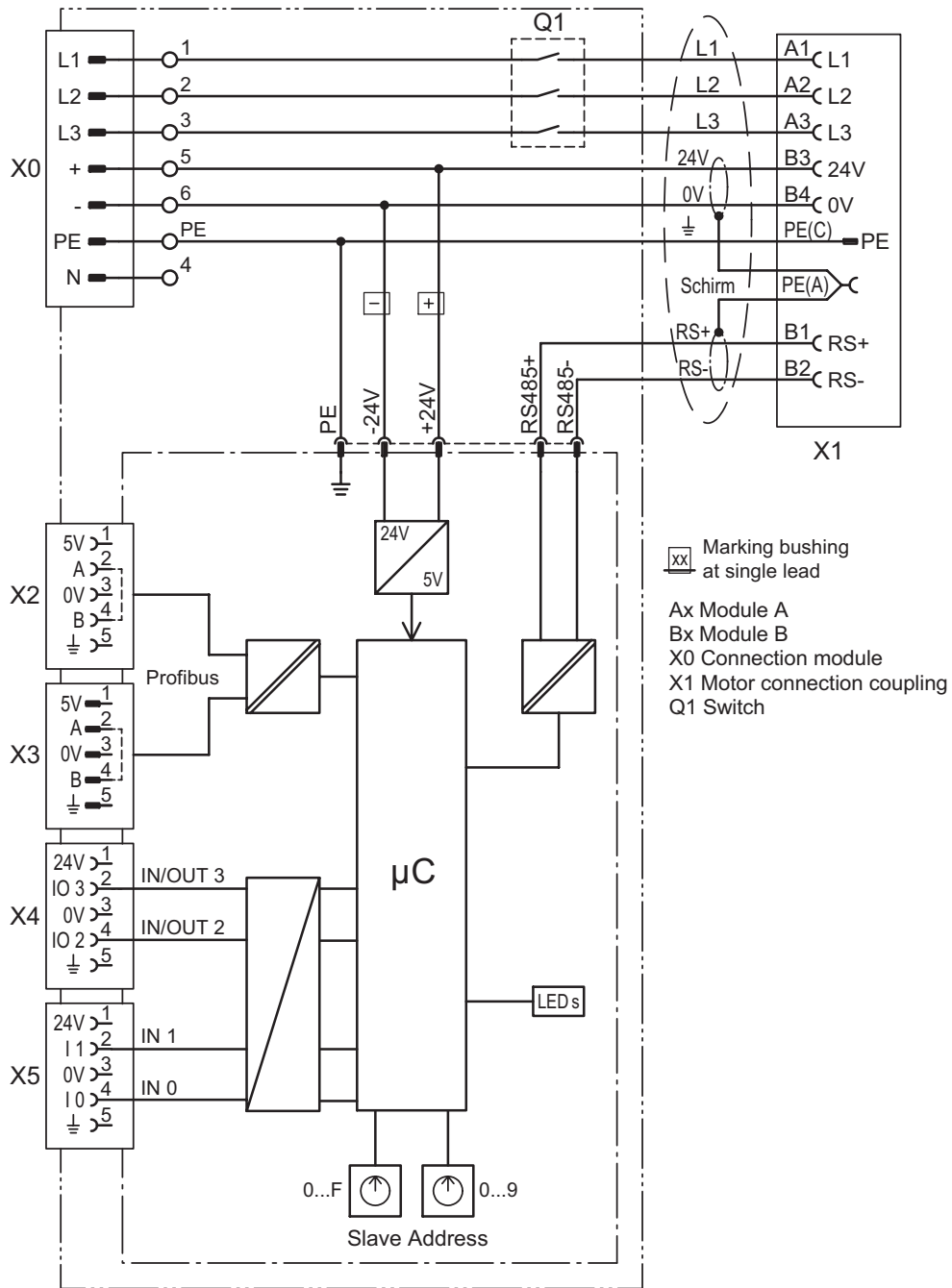

Block diagram of podis® MOT FP CP 2I2IO/RS485 SEW

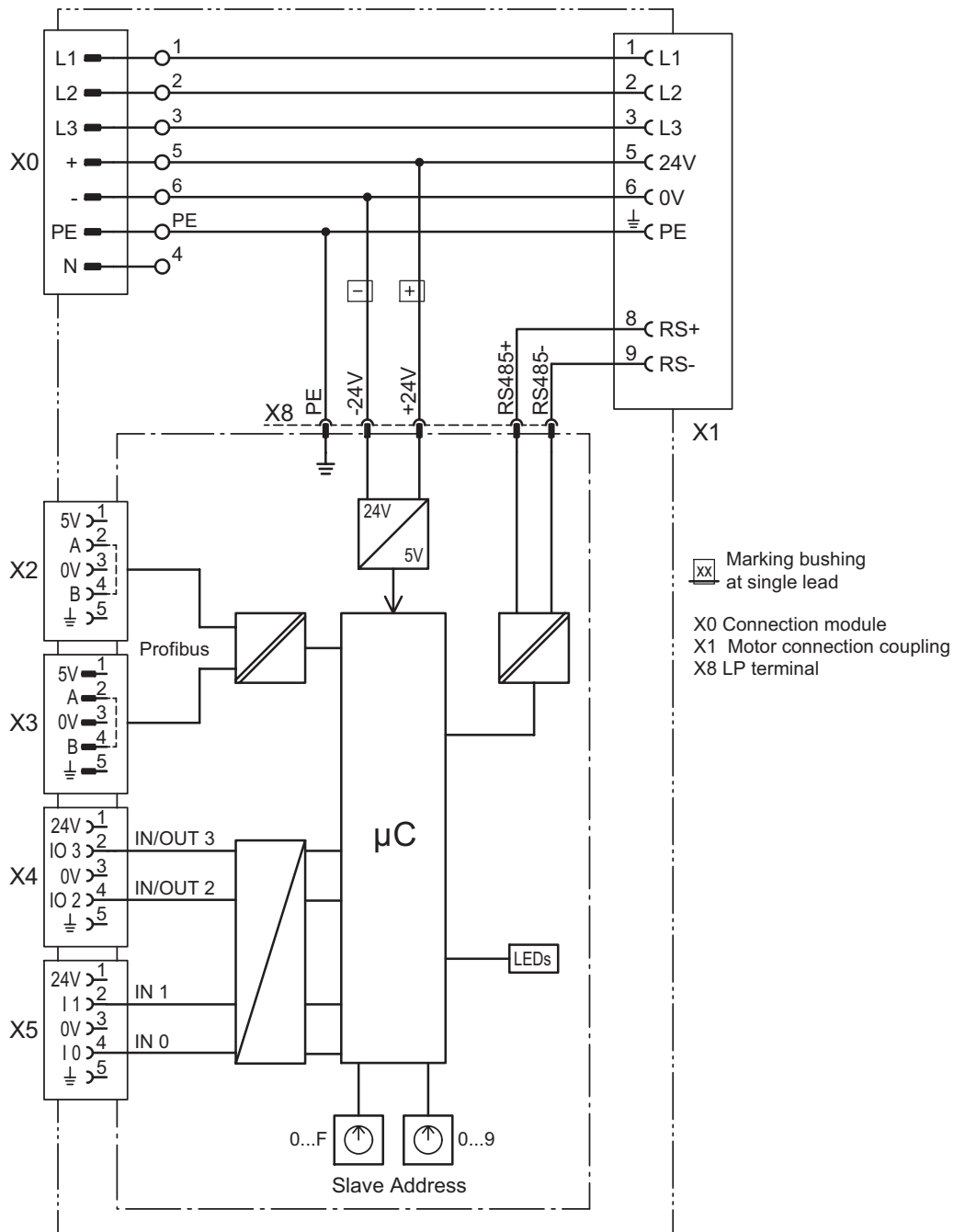

3 Mechanical Installation (Assembly)

3.1 Prerequisites

The substructure must be:

- even,
- vibration-free, and
- torsionally stiff

NOTE

The connecting line is not trailing capable.

3.2 Installation on substructure

NOTE

Use only the pre-established boreholes for the installation on the substructure. Additional boreholes at different positions are not allowed!

Fastening the device on the substructure requires three M4 screws (not supplied).

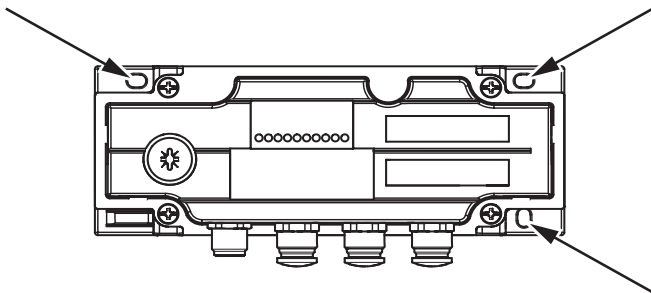

Boreholes for mounting screws

To install the unit on the substructure, proceed as follows:

1. Copy the borehole diagram (see the corresponding figure for the installation dimensions) onto the substructure.
 - The installation of the podis MOT on the substructure is carried out according to local conditions in accordance with the borehole diagram.
2. Fasten the podis MOT on the substructure using at least two M4 screws.
 - Observe the alignment according to the planned routing of the podis flat cable.
 - The podis MOT is installed on the substructure.
 - The mechanical installation is complete, the electrical installation may be started next.

Procedure

4 Electrical Installation

The podis CON manual BA000372 must be taken into account for the routing and connection of the flat cable.

- All electrical installations and connections may be performed only by trained electricians.
- The applicable safety and accident prevention regulations must be observed.
- The connectors may never be connected or disconnected under load.
- Before opening and removing the electronics cover, the entire flat cable must be de-energized.
- When routing extra-low voltage circuits together with low-voltage circuits using one line, the line must be protected against mechanical damage in areas of risk, e.g. cable channel, steel pipe or similar protection.



4.1 Connection to the podis® energy bus



| Core | PVC (gray, 7 x 2.5 mm ²) | EVA (black, 7 x 4 mm ²) |
|------|--------------------------------------|-------------------------------------|
| L1 | brown | 1 (black) |
| L2 | black | 2 (black) |
| L3 | gray | 3 (black) |
| N | blue | 4 (black) |
| PE | green/yellow | PE green/yellow |
| + | red | 5 (black) |
| - | white | 6 (black) |

The illustrated assignment of cores in the podis flat cable must be followed for the field distributor to ensure proper operation.

The auxiliary voltage for the supply of the outputs and inputs must be taken from a safely isolated power supply (PELV acc. to IEC 60364-4-41)!

NOTE

The podis flat cable is coded, thereby preventing an incorrect insertion.

The electrical connection on the energy bus flat cable is carried out by screwing in the penetrating screws.

It is recommended to use a cordless driver with adjustable torque.



CAUTION

The following notices must be observed when handling penetrating screws:

- All penetrating screws must be screwed in to the stop.
- Use a pneumatic or electrical screwdriver.
- Use Phillips no.1 screwdriver blades with a shaft length of at least 45 mm.
- Maximum torque 1 Nm.
- Screwed in penetrating screws must not be unscrewed again. When removing a podis field distributor from the flat cable, use the podis sealing sleeve (Z1.005.6553.1) to seal the contact positions.
- Only original screws from Wieland Electric may be used.
- Operation with torn off screws is not allowed.
- Cable ties must not be removed, and the cover of the penetrating screws (connecting plate) must be reinserted after complete installation.

Procedure

Proceed as follows to connect the field distributor to the energy bus:

1. Remove the fastening screws of the hood and slightly lift the hood.
2. If necessary: Remove the electrical plug connection X8 between upper and lower part and remove the upper part.

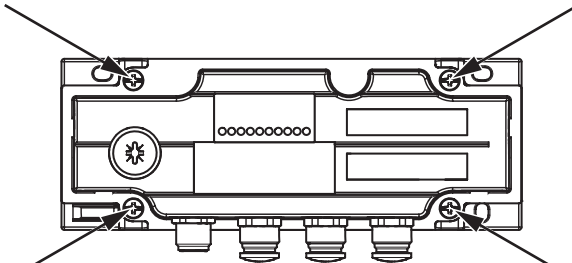

Hood fastening screws

3. Remove the two fastening screws, open up the base and place the flat cable inside in the right direction (according to the coding).

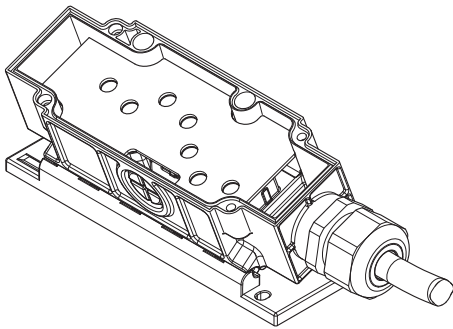

Opened base

4. Close the base and secure it with the two fastening screws.

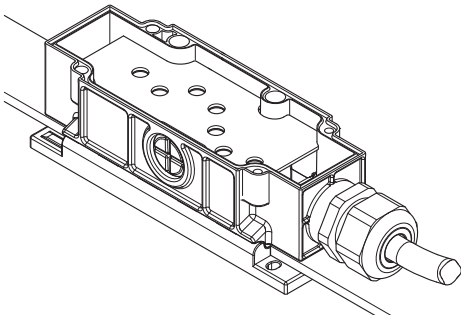

Flat cable inserted and base closed

5. Screw in the penetrating screws.
 - Screw all penetrating screws into the flat cable.
 - Torque: 1 Nm

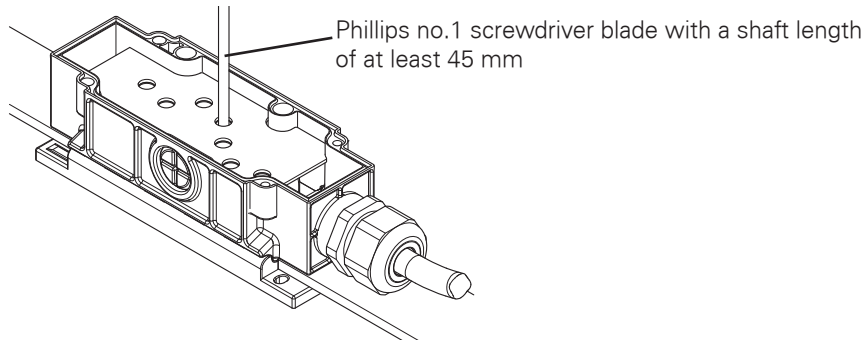

Screwing in the penetrating screws

Assignment of contact points

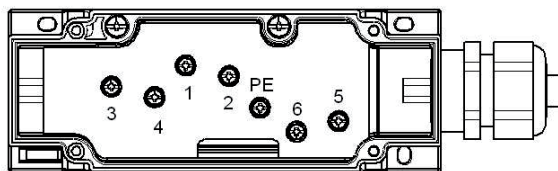

| Conductor assignment | |
|----------------------|----|
| 1 | L1 |
| 2 | L2 |
| 3 | L3 |
| 4 | N |
| 5 | + |
| 6 | - |
| PE | PE |

6. If disconnected: Reinsert the electrical plug connections between hood and base.
7. Fasten the hood with the four fastening screws.
 - Ensure that the unit is tight and that no connecting cables have been pinched.
 - The podis field distributor is connected to the energy bus.

4.3 Connection of sensor cables

The following sensors and actuators can be connected to the podis MOT FP C/CM/CP 2I2IO/RS485 SEW via the M12 sockets X4 and X5:

- Inputs: 2-wire and 3-wire sensors, p-switching
- Outputs: Semiconductor, short-circuit-proof and overload-proof

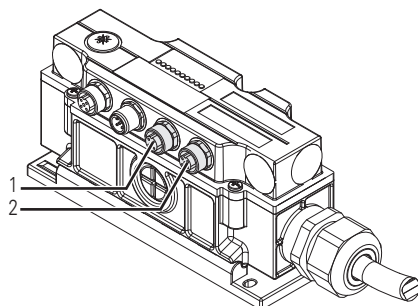

Digital inputs and outputs

| | |
|---|----------------|
| 1 | IO2 / IO3 (X4) |
| 2 | IO / I1 (X5) |



WARNING

Unused connections must be fitted with M12 caps to ensure enclosure IP65.

4.4 Connection of PROFIBUS cables

If the field distributor is integrated in a PROFIBUS cable:

1. Plug the PROFIBUS input cable onto input DP-IN (X3)
2. Plug the PROFIBUS output cable onto output DP-OUT (X2).



Field distributor in PROFIBUS line

If the field distributor is connected at the end of a PROFIBUS cable:

1. Plug the PROFIBUS input cable onto input DP-IN (X3)
2. Plug the terminating resistor onto output DP-OUT (X2).



Field distributor as PROFIBUS terminal device

4.5 MOVIMOT® connection

The MOVIMOT can be connected in different ways.

Cable ends

| Code | Cable end |
|------|--------------------|
| 5 | revos MOT |
| 6 | HAN modular insert |
| 7 | revos FLEX |
| 0 | open |

Connector assignment of HAN modular insert

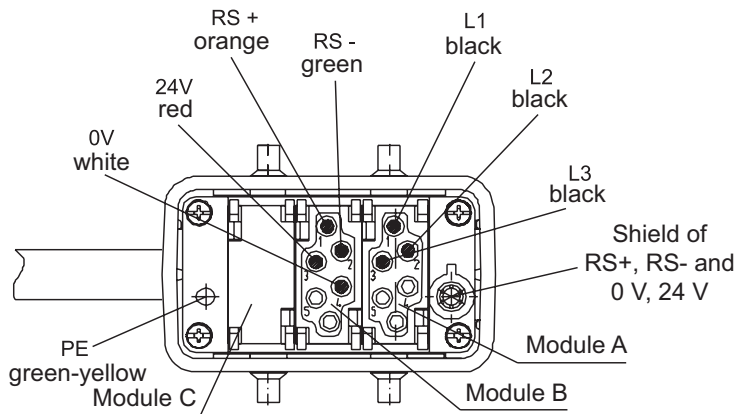

Connector assignment at podis®MOT with HAN® modular insert

NOTICE

If the variant with industrial plug connector and HAN modular insert is selected, then the "AMA6" plug option is required for MOVIMOT. Please observe the ordering notes of the drive.

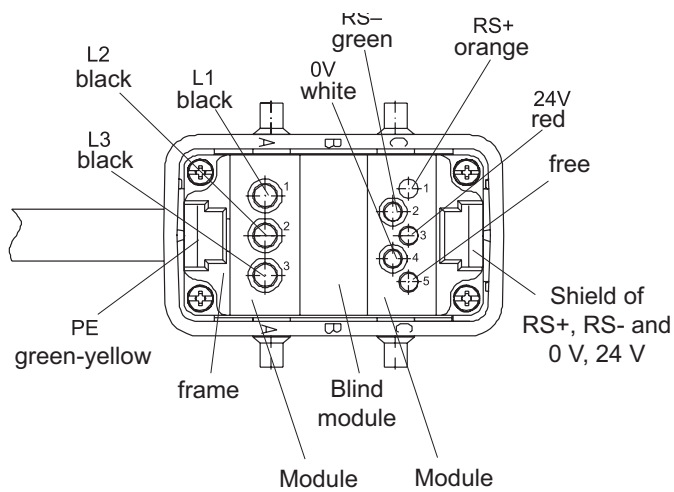

Connector assignment of revos FLEX insert

Connector assignment at podis®MOT with revos FLEX insert

DANGER

If the connector interface at the drive cannot be equipped with the correct revos FLEX connector, the connection set shown below (counterpart to the revos FLEX connector, for part no. see ordering notes/accessories on page 9.3) must be used. The use of other connection sets may lead to life-threatening conditions.

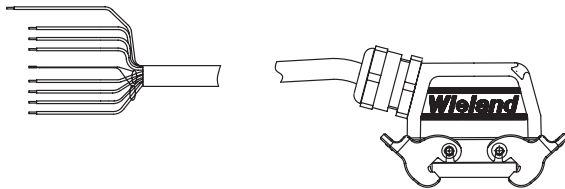

Counterpart to revos FLEX connector

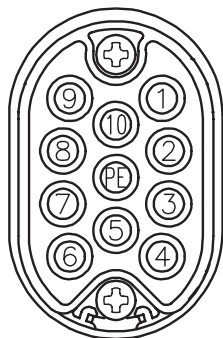

| Pin | Designation | Meaning |
|-----|-------------|---------------------------------|
| 1 | L1 | Motor lead voltage U |
| 2 | L2 | Motor lead voltage V |
| 3 | L3 | Motor lead voltage W |
| 4 | 0 V | 0 V of external voltage(*) |
| 5 | +24 V | 24 VDC of external voltage(*) |
| 6 | OUT 0 | Supply for motor electronics |
| 7 | OUT 1 | Motor control lead CW rotation |
| 8 | OUT 2 | Motor control lead CCW rotation |
| 9 | OUT 3 | Speed switching f1/f2 |
| 10 | IN 3 | Ready message from motor |
| PE | PE | PE connection |

(*) The supply is provided by an external 24-V power supply.



DANGER

If the variant with industrial plug connector and revosMOT insert is selected, the motor may be connected with the field distributor exclusively via an original Wieland hybrid cable (see ordering notes/accessories on page 9.3). The use of other cables may lead to life-threatening conditions.

Connection of open cable end

If no plug connection is desired, it can also be placed directly on the terminals of the MOVIMOT.

The following assignment must be adhered to:

| MOVIMOT® terminal | Core designation |
|-------------------|------------------|
| L1 | L1 black |
| L2 | L2 black |
| L3 | L3 black |
| PE | green/yellow |
| ⊥ (ground) | (-) 0 V white |
| +24 VDC | (+) 24 V red |
| RS+ | + RS485 orange |
| RS- | - RS485 green |
| ≡ (shield) | ≡ (shield) |

5 Commissioning

A device description file (GSD file) is used for the formal description of a PROFIBUS-DP slave. The PROFIBUS project planning tools require the information from the GSD to allow the master and the PLC system to exchange data with the slave.

GSD file (device description file)

For example, the GSD contains information about the supported transfer rates, various bus parameters, whether Freeze/Sync is supported and other features of the device. The most important information is the data width offered by the slave, i.e., how many bytes of inputs and outputs it has.

In addition, the GSD file contains references to image files (bitmaps) for the symbolic display of the module in the regular and diagnostic case.

Depending on the diagnostics tool used, the images must be copied into a specific directory before its use or the complete path including bitmaps must be specified in the GSD. Please read the description of the project planning/diagnostics tool used. The keywords in the GSD file are <Bitmap_Device> and <Bitmap_Diag>.

The GSD files contain standard error texts for the extended PROFIBUS diagnostics. The configuration tool automatically displays these diagnostics texts in case of a malfunction. This allows the user to recognize the reason for a malfunction without the PLC having to perform the error decoding.

The current GSD files of the Wieland devices can be found on the Internet under <http://www.wieland-electric.com>

The import of the GSD file in SIMATIC STEP7 is described below.

NOTE

The procedure described here and the images shown refer to SIMATIC STEP7 version 5.1. The current documentation for the STEP7 project planning software applies in each case.

5.1 Selection of the installation menu

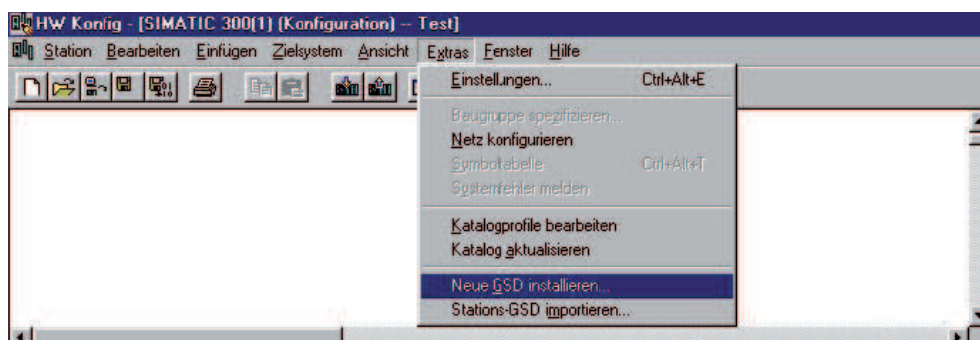

5.2 Selection of the GSD files

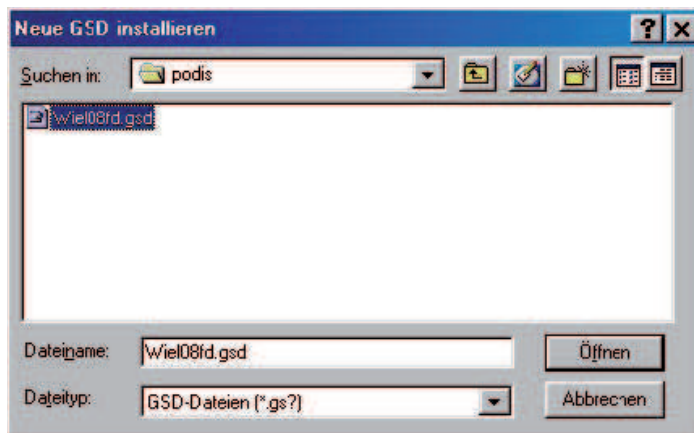

5.3 Copying the image files

Copy the image file wiel08fd.bmp into the directory \SIEMENS\STEP7\S7DATA\NSBMP\.

5.4 Updating the hardware catalog



NOTICE

In older versions of the Simatic Manager, proceed as follows:

- Copy the GSD files into the directory \SIEMENS\STEP7\S7DATA\GSD\.
- Next, select the Tools / Update GSD Files menu item in the Tools menu.

The component is now contained in the hardware catalog and available for the project planning tool.

5.5 Inserting a new hardware configuration (if needed)

Create the graphic image of your automation network.

Example: S7-300 series: CPU 315-2 DP

The hardware catalog appears from which you can now put together the S7 controller used step by step.

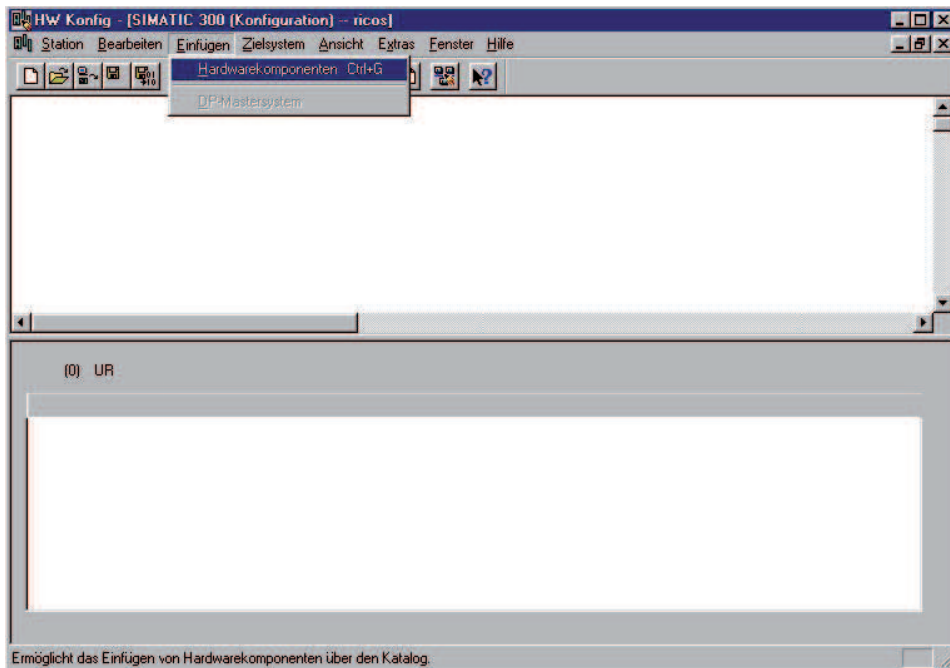

Selecting hardware components

Select a mounting rail (RACK-300) and a power supply (PS-300).

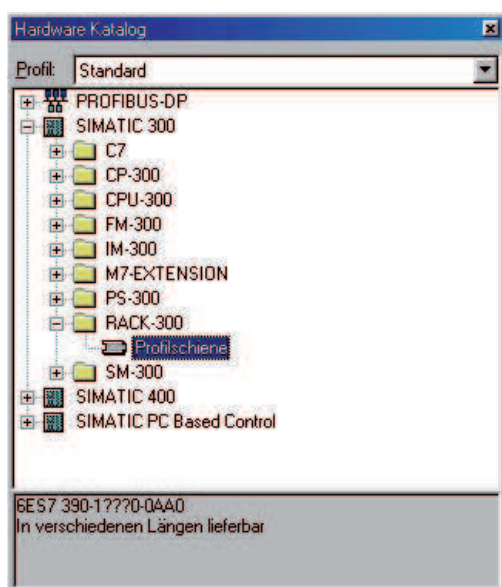

Selecting mounting rail and power supply

Selecting CPU

Select the S7-CPU used (CPU 315-2 DP).

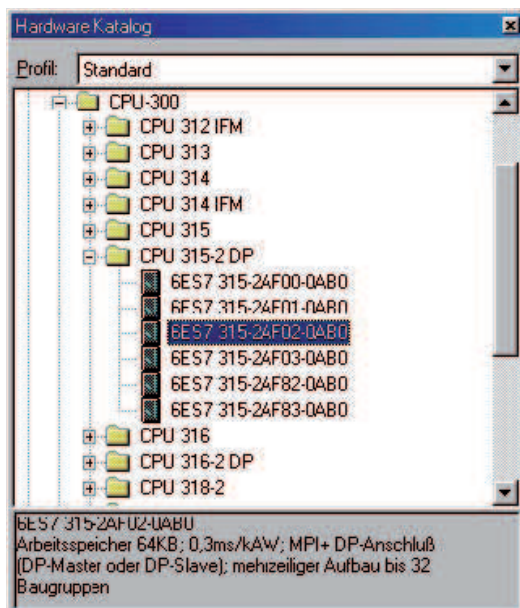

When selecting this CPU, a dialog box appears in which you must specify a PROFIBUS network.

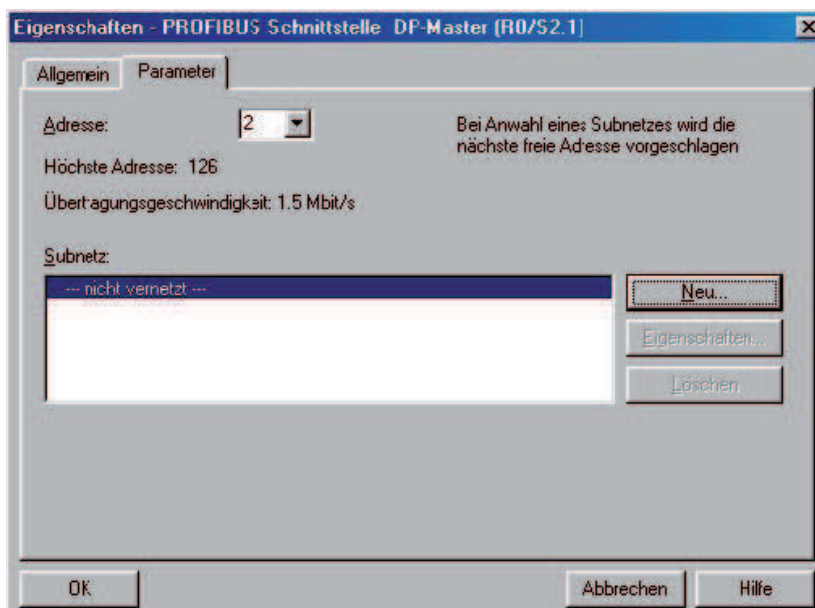

Enter the bus address of the DP master. The DP master is already integrated in the PLC you selected and requires an address, just like every other network node.

In the Subnet dialog, you define the physical key features of the PROFIBUS-DP network the way you want to use it. Press the New button and select the baud rate to be used. After returning from this dialog, a subnet is defined.

The PROFIBUS-DP network and the DP master used have now been programmed. The next step is the project planning of the DP slave modules.

For this purpose, click on the DP master system once (bold black&white line). This line changes to a solid bold black line.

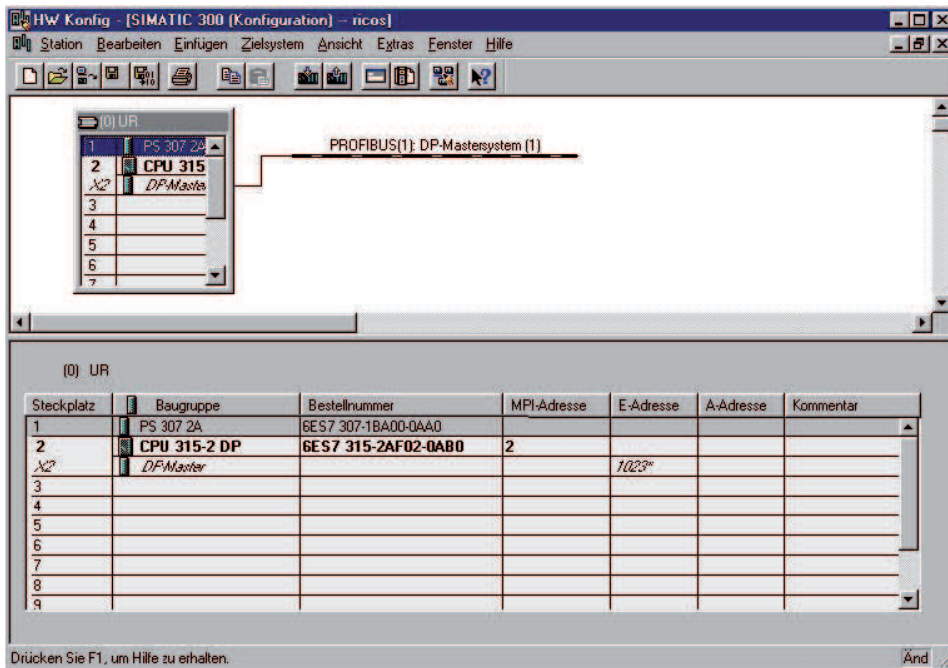

5.6 Inserting the DP slave in the PROFIBUS network

Select the module you are using from the hardware catalog under PROFIBUS-DP.

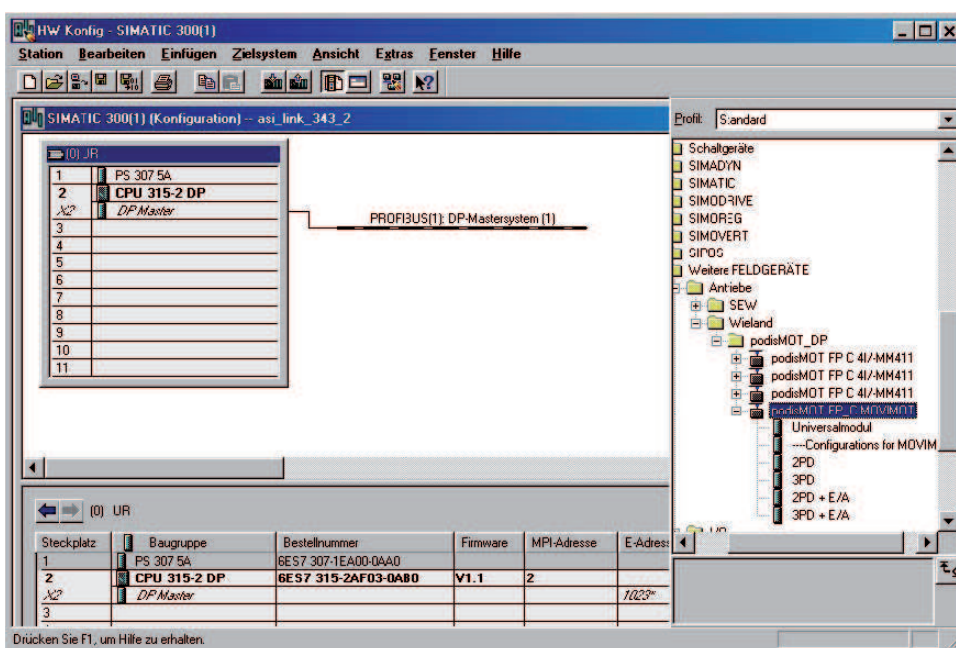

Enter the PROFIBUS-DP slave address.

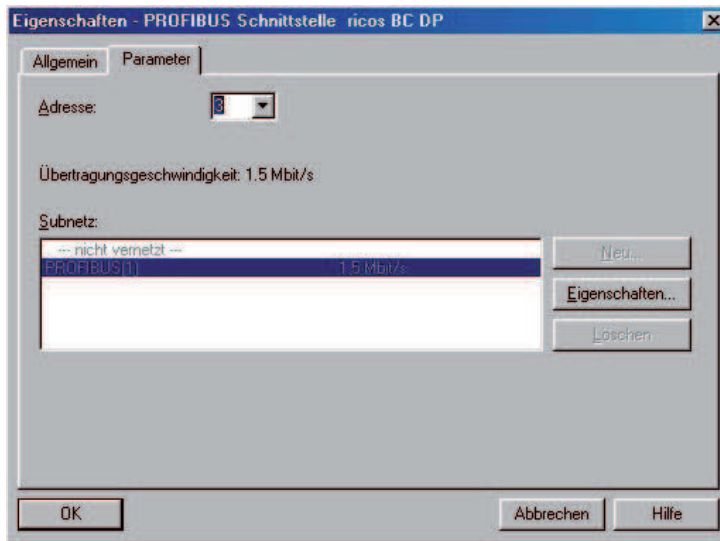

NOTICE

The specified PROFIBUS-DP slave address must be set using the rotary switches of the podisMOT. Next, switch the supply voltage of the module off and on again to activate the specified bus address.

After confirming with OK, a DP slave with three empty slots is displayed.

The slots of the DP slave are filled by clicking on the desired module configuration.

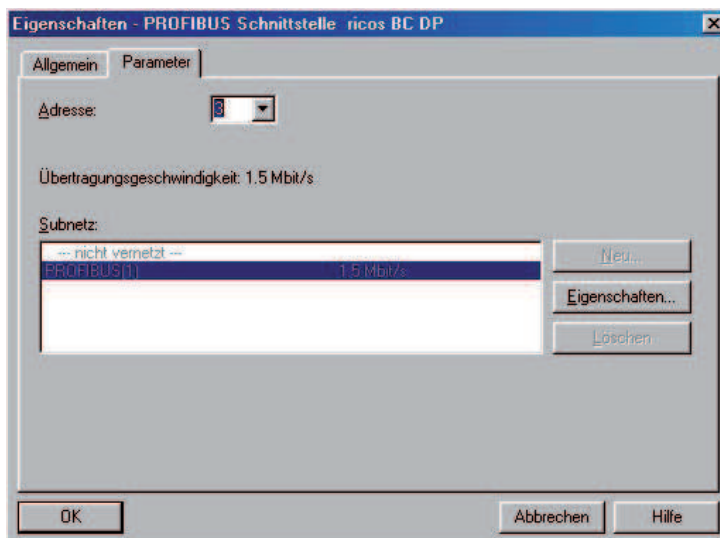

The created hardware project planning must now be transferred to the controller.

After the transfer to the CPU, the bus operation starts immediately if the slave is connected correctly, and the red LEDs "BF" at the slave and at the S7-CPU go out.

The programming system has now automatically assigned the I/O addresses for the programmed I/O modules.

In our example:

| Steckplatz | DP-Kennung | Eestellnummer / Bezeichnung | E-Adresse | A-Adresse | K |
|------------|------------|-----------------------------|-----------|-----------|---|
| 0 | 0 | 3PD + E/A | | | |
| 1 | 114 | → 3PD + E/A | 256...261 | 256...261 | |
| 2 | 82X | → 3PD + E/A | 0 | 0 | |

5.7 Parameter setting of the podisMOT properties

The STEP7 software menu item "Edit / Object Properties" allows entering an automatic parameter setting by the PROFIBUS master. These parameters allow configuring several properties for operating the DP slave.

"General" tab

Select Response Monitoring.

Response Monitoring provides you with an option for the DP slave to respond to an error from the DP master or to an interruption of the data traffic on the bus. If the DP slave is not addressed within the planned response monitoring time, the DP slave switches to safe state (all outputs set to "0" or substitute value output).

WARNING

If you deactivate the response monitoring, the outputs of the corresponding DP slave may not be set to "0" in case of an error. For this reason, it is highly recommended to deactivate the response monitoring only for commissioning.



"Parameter Setting" tab

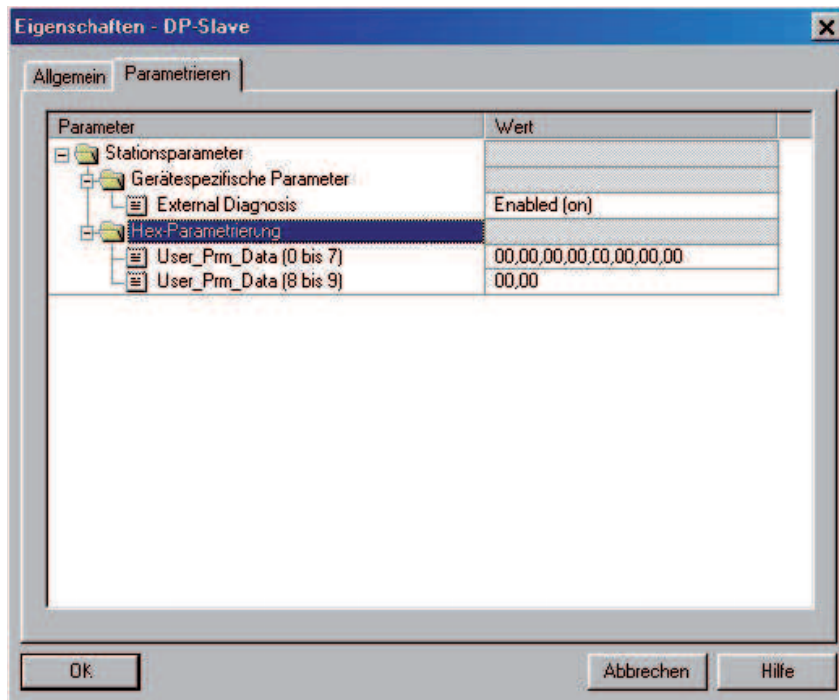

The "Parameter Setting" tab displays the parameters for the DP slave

The parameter names and the default setting of the values are defined in the GSD file for the DP slave.

Explanations for the individual parameters can be found in the manual for the DP slave.

This DP slave features the following behavior:

- No alarms can be planned at the slave.
- In the SFB54, the slave is reported as DPV0 slave.
- Diagnostic events lead to the call of OB82

Hex parameter setting

The parameter setting data are listed in hex format under the "Hex Parameter Setting" folder. A prerequisite for adjusting the values is that you are familiar with the structure of the parameter setting frame of the DP slave (see also EN 50170 or IEC 61158).

5.8 Preparing the MOVIMOT®

Operating the podis MOT requires a few settings on the MOVIMOT.

Information about the individual settings can be found in the operating instructions for MOVIMOT.

The following settings must be performed:

- Setting the RS485 slave address "1" at MOVIMOT via DIP switch S1.
- Setting the minimum frequency via potentiometer F2. The speed setpoint is preset relative as a percentage referenced to the maximum speed adjusted by means of the setpoint potentiometer F1.

The ramp setting at MOVIMOT via the potentiometer is not incorporated if the RS485 interface is used.

5.9 Addressing the field distributor

The PROFIBUS address can be set between 1 and 126.

The address assignment is carried out by positioning the two rotary switches in the electronics cover.

PROFIBUS address setting

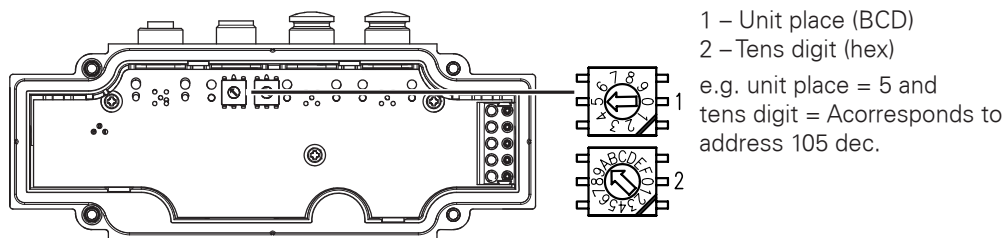

PROFIBUS-DP addressing switches (rotary switches) in electronics cover

Proceed as follows to address the field distributor:

1. Remove the four fastening screws of the electronics cover and remove it.
2. Set the configured PROFIBUS address at the two rotary switches.
3. Attach the electronics cover with the four fastening screws.
 - Ensure that the unit is tight and that no connecting cables have been pinched.
 - The field distributor is addressed.

Procedure

NOTICE

The set address is read only once upon switching on the motor. Addresses greater than "125" are recognized as "126", and a fault message is issued. The "RUN" LED flashes.

5.10 Assignment of inputs and outputs in process image

The inputs and outputs are automatically set to the next free address in the digital I/O range by STEP7.

If necessary, this address can be adjusted to the PLC application.

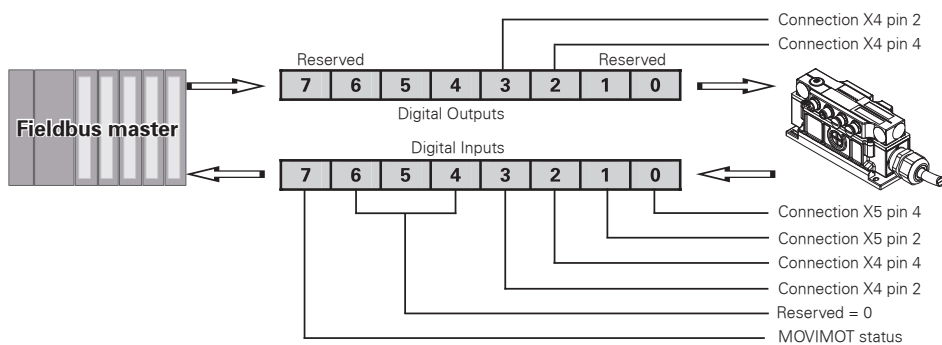

Assignment of inputs and outputs in process image

5.11 PROFIBUS functions

DP configuration

Existing functions can be deactivated, i.e. the digital inputs and outputs can be removed from the project planning by selecting the DP configuration without I/O.

It is also possible to select whether MOVIMOT should be operated with two process data words (2PD), "control word and speed". In this mode it must be ensured that the starting and brake ramp follows the ramp time set at potentiometer t1.

The following table shows all possible DP configurations that can be selected depending on the application.

| Name | Description | DP identifier | |
|-----------|---|---------------|--------|
| | | Slot 1 | Slot 2 |
| 2PD | MOVIMOT control via two process data words | 0x71 | 0x00 |
| 3PD | MOVIMOT control via three process data words | 0x72 | 0x00 |
| 2PD + I/O | MOVIMOT control via two process data words and processing of digital inputs and outputs | 0x71 | 0x30 |
| 3PD + I/O | MOVIMOT control via two process data words and processing of digital inputs and outputs | 0x72 | 0x30 |

5.12 Commissioning the field distributor

Before the initial commissioning, check the following points:

- Is a unique PROFIBUS address set? No multiple assignment of the same address.
- Are the internal terminals inserted?
- Is the cover plate attached without pinching any connecting cables?
- Is the supply voltage of 400 VAC and 24 VDC secured via the penetrating contact screws?
- Is the polarity of the 24 VDC supply correct?
- Is the PE conductor connected?
- Are the initiators correctly connected at the M12 sockets? Is the assignments of inputs correct?
- Are unused M12 sockets fitted with a cap?
- Are the M12 PROFIBUS cables correctly connected?
- If the field distributor is connected at the end of the PROFIBUS cable, is a terminating resistor connected at the M12 socket "DP-OUT"?
- Have all the necessary settings and any wiring been made at the MOVIMOT, and has the MOVIMOT housing been reinstalled?
- Is the hybrid cable connected to the MOVIMOT?
- Is the PROFIBUS master connected? Has the hardware project planning been performed?
- Is the controller set to STOP or has a tested program been loaded?

After this check has been completed, the voltage can be switched on.

It is recommended to switch on the 24 VDC supply first, followed by the supply of the PLC or the PROFIBUS master.

NOTICE

If the system does not run without faults after switching on the supply voltages and components, you should perform an error determination. See the chapter "Diagnostics (and fault removal)".

6 Operation

6.1 Functional check

Check whether the device and the control function safely. The operating state is displayed by the status LEDs (see figure in section 2.3) as follows:

| Color | Designation | Status | Meaning | Operating state |
|--------|-------------|----------------------------------|---|-----------------|
| green | RUN | constantly on flashing off | Bus is operating. PROFIBUS address is set to "0" or greater than "126dec". Missing supply voltage. | Operating state |
| red | BUS Fault | constantly on flashing off | PROFIBUS fault. PROFIBUS is active, diagnostic data are send to the PROFIBUS master. podis MOT is addressed by the PROFIBUS master. | |
| yellow | SYS Fault | constantly on | No connection to the MOVIMOT. 400 VAC voltage is missing or too low. | |
| yellow | M fwd | constantly on flashing off | Motor turns CW. Controller is disabled. Motor does not turn CW. | |
| yellow | M rev | constantly on flashing off | Motor turns CCW. Controller is disabled. Motor does not turn CCW. | |
| yellow | FU ok | constantly on | Motor is operational. | |
| yellow | IN 0 | constantly on off | Signal voltage I0 (X5) high level Signal voltage I0 (X5) low level | |
| yellow | IN 1 | constantly on off | Signal voltage I1 (X5) high level Signal voltage I1 (X5) low level | |
| yellow | IN/OUT 2 | constantly on off | Signal voltage IO2 (X4) high level Signal voltage IO2 (X4) low level | |
| yellow | IN/OUT 3 | constantly on off | Signal voltage IO3 (X4) high level Signal voltage IO3 (X4) low level | |

7 Diagnostics (and Fault Removal)

7.1 Fault removal

Malfunctions may be corrected only by qualified and authorized electricians.

If the information in the table below is not sufficient to remove the malfunction, contact the technical support of Wieland Electric.

| Status LED / malfunction | Cause | Remedy |
|--|--|---|
| 'RUN' is off | Missing 24 VDC control voltage. | Switch on the supply voltage. Check 24 VDC voltage supply. If it occurs repeatedly, replace the podisMOT. |
| 'RUN' flashes | No valid PROFIBUS address is set. | Set a valid address at the two rotary switches (valid range form 1 to 126 dec). |
| 'BUS Fault' is constantly on | PROFIBUS master is not activated. PROFIBUS cables are not (correctly) connected. | Activate the master. Check connections, cables and terminating resistor. |
| 'BUS Fault' flashes | Diagnostic data are send to the PROFIBUS master. podisMOT is not addressed under its own address. | Analyzing PROFIBUS diagnostics and data. |
| 'SYS Fault' is constantly on | Motor connector is not connected to the MOVIMOT. Internal PCB terminal is not connected. | Connect motor connector. Check hybrid cable. Connect PCB terminal. |
| 'SYS Fault' flashes | 400 VAC voltage is missing or too low. Phase error. | Connect podisMOT correctly to flat cable. Switch on mains voltage. Check wiring. |
| 'Fu ok' is constantly on and 'M fwd' flashes | MOVIMOT is operational, but inverter is not enabled | Check the application program of the user. |
| 'Fu ok' is constantly on and 'M rev' flashes | MOVIMOT is operational, but inverter is not enabled. | Check the application program of the user. |
| 'RUN' and 'BUS Fault' are constantly on | PROFIBUS fault. | Check the PROFIBUS master Check cables. |
| 'RUN' is constantly on and 'BUS Fault' flashes | podisMOT is not addressed by the master. | Check hardware configuration. |

NOTE

The application error "Multiple assignment of same PROFIBUS address" can be displayed only via the external diagnostics of the PROFIBUS master. An S7 master interface will also show this error. This should be observed particularly during the initial commissioning.

Error response to RS485 interruption

7.2 Central diagnostics via PROFIBUS-DP

An interruption of the connection between podisMOT and MOVIMOT leads to a switch-off of the connected drive after one second.

The error 921/0x5B is generated by the podisMOT and entered in status word 1, so that it can be analyzed by the PLC program.

NOTICE

Since this system error generally refers to wiring faults of the MOVIMOT inverter, it is not possible to reset the control word. As soon as the communication connection is reestablished, the fault will reset itself.

An interruption of the fieldbus master and podisMOT slave connection after the specified fieldbus timeout time causes process output data to the MOVIMOT to be set to "0".

In addition, input byte bit 7 is deleted and indicates that the MOVIMOT is not operational.

| Process input | Hex value | Meaning |
|------------------------------|--------------------------|--|
| PI1: Status word 1 | 0X5B20 | Error code 91 (5Bhex), bit 5 (fault) = "1", all other status information is invalid. |
| PI2: Actual current value | 0Xxxxx | Invalid information. |
| PI3: Status word 2 | 0X0020 | Bit 5 (fault) = "1", all other status information is invalid. |
| Input byte of digital inputs | 0X0xBit 5 to bit 7 = "0" | The input information of the digital inputs continue to be updated. |

Error response to missing or faulty supply voltage

If not mains voltage is present, error code 93/0x5D is entered in the status word. However, the error bit is not set to "1".

As soon as the supply voltage returns to the valid range, the error in the status word is deleted.

In addition, input byte bit 7 is deleted and indicates that the MOVIMOT is not operational.

| Process input | Hex value | Meaning |
|------------------------------|--------------------------|--|
| PI1: Status word 1 | 0X5D00 | Error code 93 (5Dhex), bit 5 (fault) = "0", all other status information is invalid. |
| PI2: Actual current value | 0Xxxxx | Invalid information. |
| PI3: Status word 2 | 0X0020 | All other status information is invalid. |
| Input byte of digital inputs | 0X0xBit 5 to bit 7 = "0" | The input information of the digital inputs continue to be updated. |

The PROFIBUS interface of the podisMOT reports all occurring errors to the controller via the diagnostics channel of PROFIBUS-DP. Within the controller, these error messages are analyzed via corresponding system functions (e.g. for S7-400 via diagnostics alarm OB 82/SFC13).

The following table shows the structure of the diagnostics data that are composed of the diagnostics information according to DIN EN 61158-2 and (in for MOVIMOT errors) the device-specific diagnostics data.

| Byte no. | Meaning | |
|----------|------------------------|----------------------------------|
| 0 | Station status 1 | DIN EN 61158.1 |
| 1 | Station status 2 | DIN EN 61158.1 |
| 2 | Station status 3 | DIN EN 61158.1 |
| 3 | DP master address | DIN EN 61158.1 |
| 4 | Ident number "High 08" | DIN EN 61158.1 |
| 5 | Ident number "Low FD" | DIN EN 61158.1 |
| 6 | Header | Application-specific diagnostics |
| 7 | Error code 7 | Application-specific diagnostics |

The coding of bytes 0 to 3 is defined in DIN EN 61158.1. Byte 4 and 5 generally contain the constant meanings listed in the table.

If the extended PROFIBUS diagnostics was enabled in the GSD file, a connection interruption to MOVIMOT results in error code 0x5B to be transferred to the controller in byte 7 (diagnostics byte).

Since all the fault information is also transferred directly to the controller via the status words of the process input data, triggering the diagnostics alarm by a MOVIMOT fault can be deactivated via the user-specific parameters of PROFIBUS-DP.

NOTICE

This mechanism merely deactivates the triggering of a diagnostics alarm due to a MOVIMOT fault. Diagnostics alarms can, however, be triggered at any time in the PROFIBUS-DP master by the PROFIBUS-DP system. The corresponding organizational modules (e.g. OB82 for S7-400) should generally be set up in the controller.

During the project planning of a PROFIBUS-DP slave, additional user-specific parameters that are transferred to the slave during the initialization of the PROFIBUS-DP can be defined in every PROFIBUS-DP master.

Ten user-specific parameter data are reserved for the MFP interface. Byte 1 is assigned the following function:

| Parameter data (hex) | Function |
|--|---|
| 00, 00, 00, 00, 00, 00, 00, 00, 00, 00 | Diagnostics alarms are also generated in case of an error |
| 00, 01, 00, 00, 00, 00, 00, 00, 00, 00 | Diagnostics alarms are not generated in case of an error |

**PROFIBUS-DP
slave diagnostics data**

**Switching
alarms on and
off**

**Project planning
examples**

7.3 Replacing the electronics module

The electronics module is built into the hood (electronics cover).



WARNING

All electrical installations and connections may be performed only by trained electricians. The applicable safety and accident prevention regulations must be observed. Before opening and removing the electronics cover, the entire flat cable must be de-energized.

Proceed as follows to replace the electronics module:

1. Remove the four fastening screws of the electronics cover.
 2. Unplug connector X8.
 3. Replace the complete electronics cover with a new one.
 4. Set the PROFIBUS address.
 4. Plug the connector X8 into the connection in the electronics cover.
 5. Attach the electronics cover with the four fastening screws.
- Ensure that the unit is tight and that no connecting cables have been pinched.
 - The electronics module has been replaced.

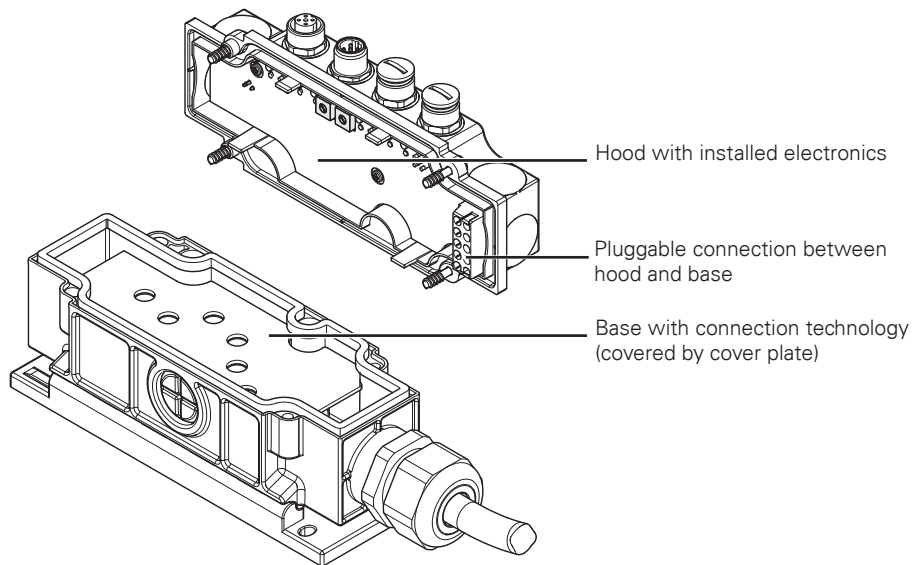

podis®MOT (opened)

8 MOVILINK® Device Profile

8.1 Coding of process data

The same process data information is used across all fieldbus systems for the control and setpoint input. The coding of the process data is carried out according to the uniform MOVILINK profile for SEW drive inverters. For MOVIMOT, it is generally possible to differentiate the following variants:

- Two process data words (2PD)
- Three process data words (3PD)

| PO | Process output data | PI | Process input data |
|-----|---------------------|-----|--------------------|
| PO1 | Control word | PI1 | Status word 1 |
| PO2 | Speed (%) | PI2 | Output current |
| PO3 | Ramp | PI3 | Status word 2 |
| DO | Digital outputs | DI | Digital inputs |

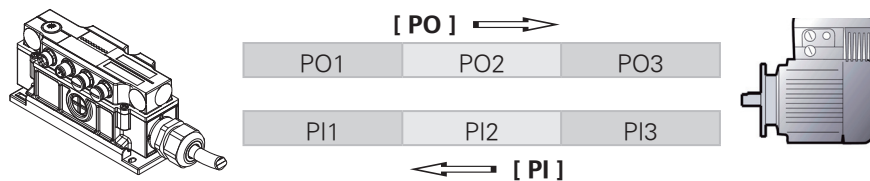

Communication between podis®MOT and MOVIMOT®

podisMOT also allows the additional connection of sensors and actuators at digital input and output terminals via the two M12 sockets X4 and X5.

In the PROFIBUS-DP protocol, an additional I/O byte is attached after the process data for MOVIMOT in which the additional digital inputs and outputs are mapped.

The coding is once again carried out according to the uniform MOVILINK profile for SEW drive inverters.

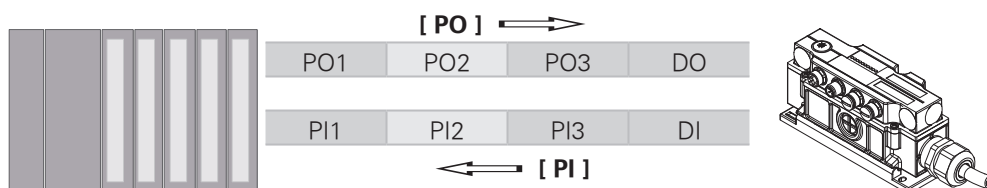

Communication between master and slave

To control MOVIMOT via two process data words (2PD), the process output data control word and speed (%) are sent from the higher-level automation device to MOVIMOT and the process input data status word 1 and output current are transferred from MOVIMOT to the automation device.

Control via two process data words

For control via three process data words, the ramp is transferred as additional process output data word and status word 2 as the third process input data word.

Control via three process data words

8.2 Process output data

Process output data are transferred from the higher-level controller via podisMOT to MOVIMOT (control information and setpoints). However, they only become active in MOVIMOT if the RS485 address in MOVIMOT is set differently than "0".

MOVIMOT can be controlled with the following process output data:

- PO1: Control word
- PO2: Speed (%) (setpoint)
- PO3: Ramp

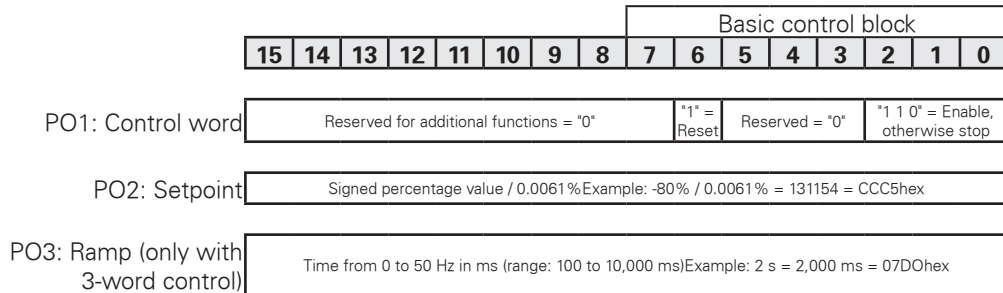

**Control word
Bit 0 to 2**

The setting of the "Enable" control command is carried out with bit 0 to 2 by setting the control word = 0006hex. To enable MOVIMOT, the CW and/or CCW input terminal must also be switched to +24 V (bridged).

The control command "Stop" is carried out by resetting bit 2 = "0". For compatibility reasons to other SEW inverter families, you should use the stop command 0002hex. On principle, MOVIMOT initiates a stop at the current ramp with bit 2 = "0", regardless of the state of bit 0 and bit 1.

**Control word
Bit 6 = Reset**

In case of a malfunction, the fault can be acknowledged with bit 6 = "1" (reset). Unused control bits should feature the value "0" for compatibility reasons. See the MOVIMOT fault table.

The speed setpoint is preset relative as a percentage referenced to the maximum speed adjusted by means of the setpoint potentiometer f1.

Calculation the speeds

Coding: C000hex = -100 % (CCW rotation)
 4000hex = 100 % (CW rotation)
 1 digit = 0.0061 %

Example: 80 % fmax, CCW direction of rotation
 -80 % / 0.0061 = -13115dec = CCC5hex

| Percent | CW rotation | | CCW rotation | |
|---------|-------------|------|--------------|------|
| | Dec | Hex | Dec | Hex |
| 100 | 16384 | 4000 | -16384 | C000 |
| 95 | 15565 | 3CCC | -15565 | C334 |
| 90 | 14746 | | | |
| 85 | 13926 | 3666 | -13926 | C99A |
| 80 | 13107 | 3333 | -13107 | CCCD |
| 75 | 12288 | 3000 | -12288 | D000 |
| 70 | 11469 | 2CCC | -11469 | D334 |
| 65 | 10650 | 2999 | -10650 | D667 |
| 60 | 9830 | 2666 | -9830 | D99A |
| 55 | 9011 | 2333 | -9011 | DCCD |
| 50 | 8192 | 2000 | -8192 | E000 |
| 45 | 7373 | 1CCC | -7373 | E334 |
| 40 | 6554 | 1999 | -6554 | E667 |
| 35 | 5734 | 1666 | -5734 | E99A |
| 30 | 4915 | 1333 | -4915 | ECCD |
| 25 | 4096 | 1000 | -4096 | F000 |
| 20 | 3277 | 0CCC | -3277 | F334 |
| 15 | 2458 | 0999 | -2458 | F667 |
| 10 | 1638 | 0666 | -1638 | F99A |
| 5 | 819 | 0333 | -819 | FCCD |
| 1 | 164 | A3 | -164 | FF5D |
| 0,1 | 16 | 10 | -16 | FFF0 |

Calculation of ramp times

If the process data exchange is carried out via three process data, the current integrator ramp is transferred to MOVIMOT in the process output data word PA3.

If the process data exchange is carried out via two process data, the ramp set with switch t1 is used.

Coding: 1 digit = 1 ms

Range: 100...10000 ms

Example: 2.0 s = 2000 ms = 2000dec = 07D0hex

| Time [s] | Setting [ms] | |
|----------|--------------|------|
| | Dec | Hex |
| 0,5 | 500 | 1F4 |
| 1 | 1000 | 3E8 |
| 1,5 | 1500 | 5DC |
| 2 | 2000 | 7D0 |
| 2,5 | 2500 | 9C4 |
| 3 | 3000 | BB8 |
| 3,5 | 3500 | DAC |
| 4 | 4000 | FA0 |
| 4,5 | 4500 | 1194 |
| 5 | 5000 | 1388 |
| 5,5 | 5500 | 157C |
| 6 | 6000 | 1770 |
| 6,5 | 6500 | 1964 |
| 7 | 7000 | 1B58 |
| 7,5 | 7500 | 1D4C |
| 8 | 8000 | 1F40 |
| 8,5 | 8500 | 2134 |
| 9 | 9000 | 2328 |
| 9,5 | 9500 | 251C |
| 10 | 10000 | 2710 |

8.3 Process input data

Process input data are returned to the higher-level controller from the MOVIMOT inverter via podisMOT and consist of status and actual value information.

The following process input data are supported by MOVIMOT:

- PI1: Status word 1
- PI2: Output current
- PI3: Status word 2

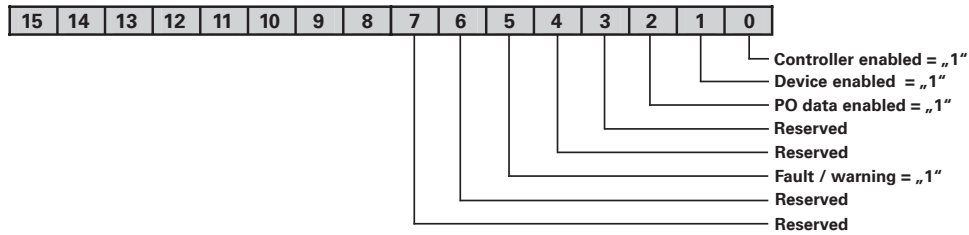

PI1:
Status word 1

Device status (bit 5 = "0")

- 0: inverter not ready
- 2: No enable
- 4: Enabled

Fault number (bit 5 = "1")

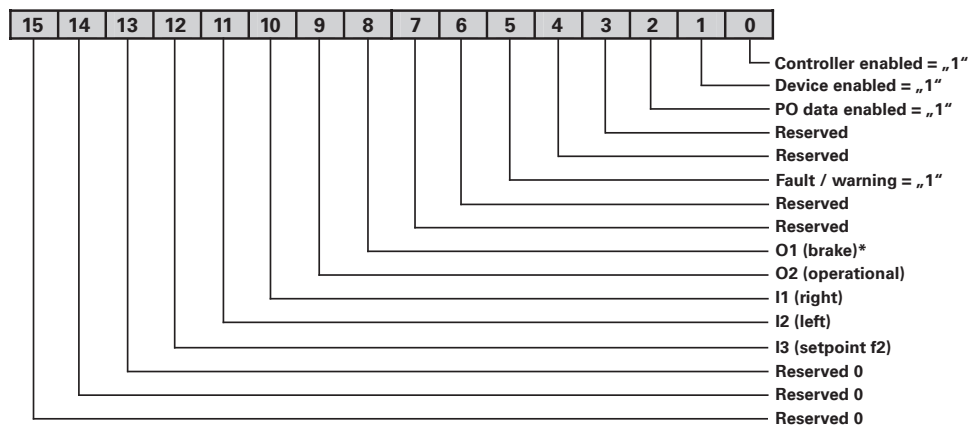

- * O1 (brake)
- "1" = brake closed
- "0" = brake released

Current actual value

16 bit integer with sign x 0.1 % I_N
 Example: 0320hex = 800 x 0.1 % I_N = 80 % I_N

PI2:
Output current

NOTICE

The status word 2 is used only for the 3-word protocol.

PI3:
Status word 2

8.4 Program example in conjunction with SIMATIC® S7 and fieldbus

The processing of process data as well as the digital inputs and outputs of podisMOT is illustrated based on a program example for SIMATIC S7.

Address assignment in automation device

In the example, the process data of the MOVIMOT fieldbus interface are stored in the PLC memory range PW132 - PW136.

The additional output or input data word is managed in AW 100 or EW 100.

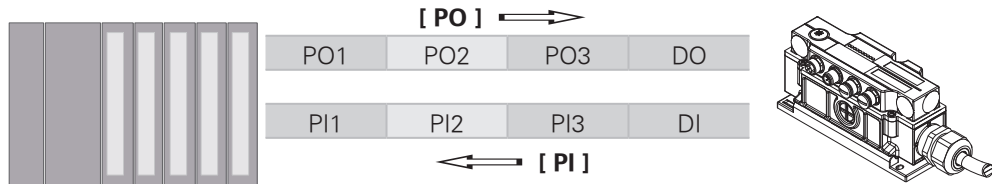

| [1] Address area | PO Process output data | PI Process input data |
|----------------------|-------------------------------|------------------------------|
| [2] Output addresses | PO1 Control word | PI1 Status word 1 |
| [3] Input addresses | PO2 Speed [%] | PI2 Output current |
| | PO3 Ramp | PI3 Status word 2 |
| | DO Digital outputs | DI Digital inputs |

Control of MOVIMOT with STEP7

The MOVIMOT drive is released with input 4.0.

- E 100.0 = "0": Control command "Stop"
- E 100.0 = "1": Control command "Enable"

The drive is accelerated or decelerated with an integrator ramp of one second.

The process input data are buffered in flag word 20 to 24 for further processing.

Sample program

```

U   E 100.0 // Give control command "Enable" with input 100.0
SPB FREI

L   W#16#2 //Control command "Stop"
T   PAW 132 // Write to PO1 (control word 1)
SPA SOLL

FREI: L   W#16#6 // MOVIMOT control command "Enable" (0006hex)
T   PAW 132 // Write to PO1 (control word 1)

SOLL: U   E 100.1 // Set direction of rotation with input 100.1.
SPB LINK // When input 100.1 = "1", then CCW
L   W#16#2000 // Set speed = 50% fmax CW rotation (=2000hex)
T   PAW 134 // Write to PO2 (speed [%])
SPA ISTW

LINK: L   W#16#E000 // Set speed = 50% fmax CCW rotation (=E000hex)
T   PAW 134 // Write to PO2 (speed [%])

ISTW: L   1000 // Ramp = 1s (1000dec)
T   PAW 136 // Write to PO3 (Ramp)

L   PEW 132 // Load PI1 (status word 1)
T MW 20 // and save in buffer
L   PEW 134 // Load PI2 (output current)
T MW 22 // and save in buffer
L   PEW 136 // Load PI3 (status word 2)
T MW 24 // and save in buffer

BE
    
```

9 Appendix

9.1 Technical data

| | |
|--|---|
| Electronics supply <ul style="list-style-type: none"> • Input voltage • Power consumption • MOVIMOT power consumption • MOVIMOT switch-on current | 24 VDC \pm 20 % (19.2 V ... 28,8V) approx. 2 W (without MOVIMOT) approx. 0.2 W 1 A |
| AC input voltage at X0 <ul style="list-style-type: none"> • Input voltage V_{supply} • Supply frequency input | 230/400 VAC 50 Hz \pm 10 % (45 Hz ... 55 Hz) |
| AC output voltage at X1 <ul style="list-style-type: none"> • Output voltage • Output current per phase • Output frequency • Length of hybrid cable (load connection) | V_{supply} (input voltage) max. 16 A 50 Hz \pm 10 % (45 Hz ... 55 Hz) max. 5 m |
| Digital inputs <ul style="list-style-type: none"> • Digital inputs • Input current • Signal level $V_{\text{high}} / V_{\text{low}}$ • Initiator cable length | X4 (IO2, IO3), X5 (I0, I1) typ. 5 mA +15 V ... +31,5V / -3V ... +5V max. 5 m |
| Digital outputs <ul style="list-style-type: none"> • Digital outputs • Voltage • Current • Outputs (hybrid line) | X4 (IO2, IO3) 24 VDC \pm 20 % 1 A (total current O2, O3) RS485 interface, integrated bus termination; 24 VDC supply voltage, damping diode; L1, L2, L3 and PE, cable length max. 5 m |
| PROFIBUS-DP <ul style="list-style-type: none"> • PROFIBUS connection • Transfer rate in kbaud • Address setting | DP-IN X3 (M12 plug) DP-OUT X2 (M12 socket) 9.6 / 19.2 / 45.45 / 93.75 / 187.5 / 500 / 15000 / 3000 / 6000 / 12000 max. 125 (set via rotary switches) |
| General data <ul style="list-style-type: none"> • Environmental conditions (overall system) • Pollution degree • Overvoltage category • Fire behavior of contact carriers • Temperature - operating environment • Temperature - storage/transport • Vibration • Air humidity • Enclosure • Protection class • Protection category • Mounting position • Dimensions W x H x L | Industrial atmosphere III 3 min. UL94V2 0...50 °C -25 °C...60 °C / -25 °C...+70 °C IEC 721 Class 3M6 100 %, non-condensing IP 65 acc. to EN 60529 Class 1 acc. to IEC536 3 any (preferably horizontal wall mounting) see installation dimensions in chapter 2.8 |

9.2 Ordering information

| Field distributor | |
|---|---------------|
| • podis MOT FP CP 2I2IO/RS485 SEW (revosMOT) | 83.252.0005.2 |
| • podis MOT FP C 2I2IO/RS485 SEW (AMA6) | 83.252.xx06.2 |
| • podis MOT FP C 2I2IO/RS485 SEW (revosFLEX) | 83.252.xx07.2 |
| • podis MOT FP C 2I2IO/RS485 SEW (open end) | 83.252.xx00.2 |
| • podis MOT FP CM 2I2IO/RS485 SEW (AMA6)+Rep. | 83.252.xx06.4 |
| • podis MOT FP CM 2I2IO/RS485 SEW (revos FLEX)+Rep. | 83.252.xx07.4 |
| • podis MOT FP CM 2I2IO/RS485 SEW (open end)+Rep. | 83.252.xx00.4 |

Order number key

The coding of the article number, particularly the information about line length ("xx"), can be taken from the following order number key.

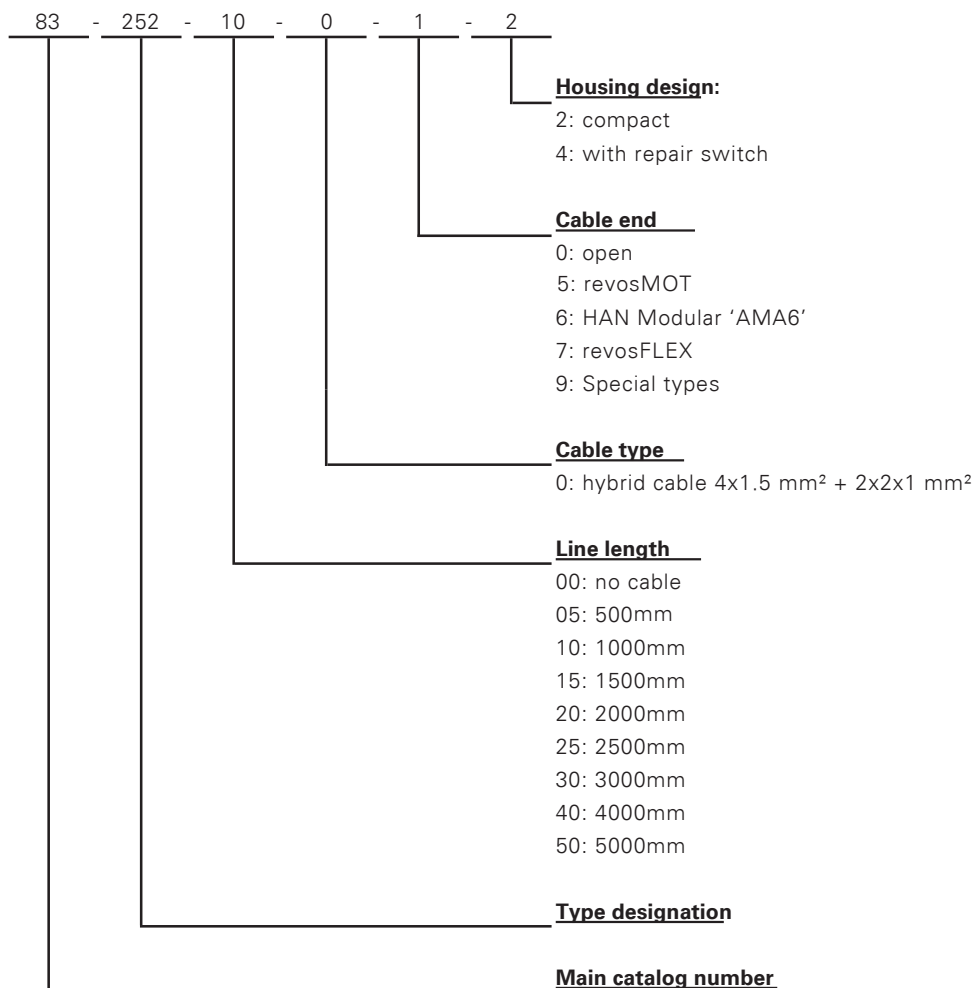

podis®MOT FP C 2I2IO/RS485 SEW

podis® field distributor for PROFIBUS-DP control with energy supply for MOVIMOT® from SEW-Eurodrive based on MOVILINK® protocol, preassembled with hybrid cable 4x2.5 + 2x2x1.0(C) sw and **AMA 6 connector interface** at MOVIMOT®

83.252.1006.2

Length of hybrid cable 1.0 m

same as 83.252.1006.2, but line length 1.5 m 83.252.1506.2

same as 83.252.1006.2, but line length 2.0 m 83.252.2006.2

same as 83.252.1006.2, but line length 2.5 m 83.252.2506.2

same as 83.252.1006.2, but line length 3.0 m 83.252.3006.2

Ordering information**podis®MOT FP C 2I2IO/RS485 SEW**

podis® field distributor for PROFIBUS-DP control with energy supply for MOVIMOT® from SEW-Eurodrive based on MOVILINK® protocol, assembled with hybrid cable 4x2.5 + 2x2x1.0(C) sw and **connector revos FLEX**

83.252.1007.2

Length of hybrid cable 1.0 m

same as 83.252.1007.2, but line length 1.5 m 83.252.1507.2

same as 83.252.1007.2, but line length 2.0 m 83.252.2007.2

same as 83.252.1007.2, but line length 2.5 m 83.252.2507.2

same as 83.252.1007.2, but line length 3.0 m 83.252.3007.2

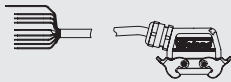
Accessories for podis®MOT FP C 2I2IO/RS485 SEW

Assembled hybrid cable 4x2.5 + 2x2x1.0(C) sw, length 0.5 m and connector (pin inserts) revos FLEX, open end fully prepared for connection to drive for revos FLEX

99.700.1357.1

| | | |
|---|--|---------------|
| podis®MOT FP CP 2I2IO/RS485 SEW | | |
|  | podis® field distributor for PROFIBUS-DP control with energy supply for MOVIMOT® from SEW-Eurodrive acc. to MOVILINK® protocol, with connector interface revosMOT at podis® field distributor | 83.252.0005.2 |

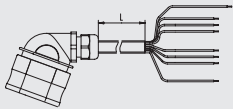
| | | |
|---|---|---------------|
| Accessories for podis®MOT FP CP 2I2IO/RS485 SEW | | |
|  | Assembled connecting cable for MOVIMOT® from SEW-Eurodrive; connector: revosMOT angled, Cable: hybrid cable with 4x2.5 mm² (for power) 2x1.0 mm² shielded (for RS+ and RS-), black open cable end; shield stripping length 190 mm, insulation stripping length 7 mm; ultrasound-compacted, cable length 1.0 m | 83.314.1002.1 |
| | same as 83.314.1002.1, but line length 1.5 m | 83.314.1502.1 |
| | same as 83.314.1002.1, but line length 2.0 m | 83.314.2002.1 |
| | same as 83.314.1002.1, but line length 3.0 m | 83.314.3002.1 |
| | same as 83.314.1002.1, but line length 4.0 m | 83.314.4002.1 |
| | same as 83.314.1002.1, but line length 5.0 m | 83.314.5002.1 |

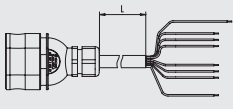
| | | |
|---|---|---------------|
| Accessories for podis®MOT FP CP 2I2IO/RS485 SEW | | |
|  | Assembled connecting cable for MOVIMOT® from SEW-Eurodrive; connector: revosMOT straight, Cable: hybrid cable with 4x2.5 mm² (for power) 2x1.0 mm² shielded (for RS+ and RS-), black open cable end; shield stripping length 190 mm, insulation stripping length 7 mm; ultrasound-compacted, length: 1,0m | 83.314.1006.1 |
| | same as 83.314.1006.1, but line length 1.5 m | 83.314.1506.1 |
| | same as 83.314.1006.1, but line length 2.0 m | 83.314.2006.1 |
| | same as 83.314.1006.1, but line length 3.0 m | 83.314.3006.1 |
| | same as 83.314.1006.1, but line length 4.0 m | 83.314.4006.1 |
| | same as 83.314.1006.1, but line length 5.0 m | 83.314.5006.1 |

| | | |
|---|--|---------------|
| podis®MOT FP CM 2I2IO/RS485 SEW | | |
|  | podis® field distributor PROFIBUS-DP same as 83.252.1006.2, but with repair switch and hybrid cable 1.0 m | 83.252.1006.4 |
| | same as 83.252.1006.4, but line length 1.5 m | 83.252.1501.4 |
| | same as 83.252.1006.4, but line length 2.0 m | 83.252.2001.4 |
| | same as 83.252.1006.4, but line length 2.5 m | 83.252.2501.4 |
| | same as 83.252.1006.4, but line length 3.0 m | 83.252.3001.4 |

PROFIBUS-DP accessories

M12 – PROFIBUS-DP Connecting cable RVDP 83.403.0611.9
 SW12 BW12 06M12/M12 connecting cable;
 B-coded; shielded for PROFIBUS-DP; connector
 angled to socket angled, cable length 0.6 m

M12 – PROFIBUS-DP Connecting cable RVDP 83.403.1011.9
 SW12 BW12 10same as 83.403.0611.9, but
 cable length 1.0 m

M12 – PROFIBUS-DP Connecting cable RVDP 83.403.2011.9
 SW12 BW12 20same as 83.403.0611.9, but
 cable length 2.0 m

M12 – PROFIBUS-DP Connecting cable RVDP 83.403.3011.9
 SW12 BW12 30same as 83.403.0611.9, but
 cable length 3.0 m

M12 – PROFIBUS-DP Connecting cable RVDP 83.403.5011.9
 SW12 BW12 50same as 83.403.0611.9, but
 cable length 5.0 m

M12 – PROFIBUS-DP Connecting cable RVDP 83.403.7011.9
 SW12 BW12 70same as 83.403.0611.9, but
 cable length 7.0 m

M12 – PROFIBUS-DP Connecting cable RVDP 83.403.9911.9
 SW12 BW12 100same as 83.403.0611.9, but
 cable length 10.0 m

Accessories (general)

- M12 T-distributor (A-coded for sensor cable 0.3 m) 83.408.0310.0
- Sealing sleeve Z1.005.6553.1

Spare parts

- Electronics module 83.209.2110.2
- Motor cable, complete Upon request



wieland

**Electrical
Connections**

Wieland Electric GmbH
Brennerstraße 10-14
96052 Bamberg

Tel. +49 (0) 951 / 9324 -0
Fax +49 (0) 951 / 9324 -198
Email info@wieland-electric.com
www.wieland-electric.de